



TRANSFORMER BOBBIN  
INDUSTRIAL CO.,LTD.

Tel : 86-769-88789999 Fax : 86-769-88789989  
 http:// tbi-tw.com e-mail : tb6688@ms46.hinet.net

REVISIONS

REV	SYM	DRAFTER	CHECKER	DATE
△1	X.X.YUAN	G.F.YANG	W.H.HSU	12/10/12
△2				
△3				

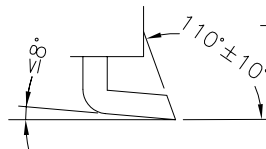
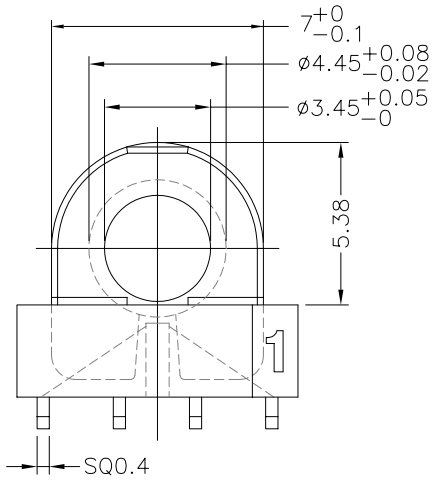
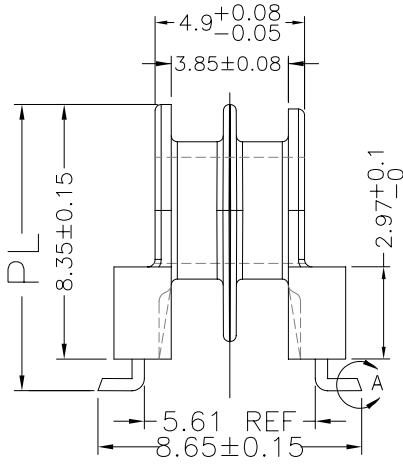
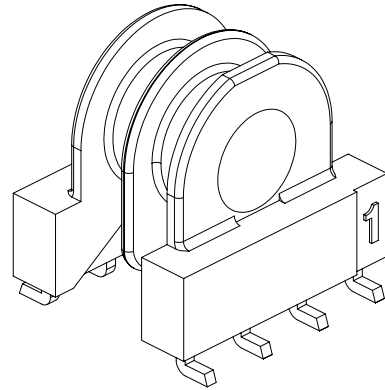
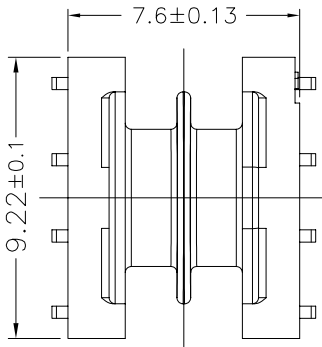

DETAIL : A  
(PATENTED)

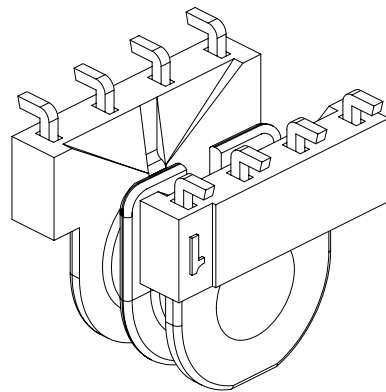
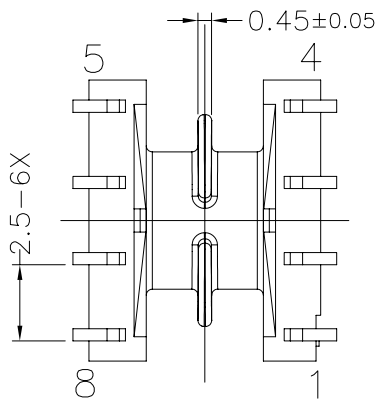

DWG NO. EP7-8P-L-2.5V-F6-1-2S

PART NO.	MATERIAL (BOBBIN)	MATERIAL (TERMINAL)	TERMINAL (PLATING)	PIN ALLOCATION	NOTE
TBI-103-08662.103	PM-9630	P.B	Sn	ALL PIN (PL)=9.45+0/-0.25	H
TBI-103-08662.113	PM-9630	P.B	Sn	ALL PIN (PL)=10.35+/-0.25	

TOLERANCE: .X±0.15 .XX±0.10 .XXX±0.05 UNIT : m / m SCALE 4 : 1

Finish: 1. Immersion gold on terminal : Thickness gold 0.075 μm (3 μ inches) min, Base nickel 0.625 μm (25 μ inches) min.  
 2. Immersion Sn on terminal : Terminal:Sn plating, 100, 5 μm (200 μ inches) min , Base nickel 0.625 μm (25 μ inches) min.  
 3. Coplanarity deviation: 0.10 mm (0.004 inches) max.

REV 1