

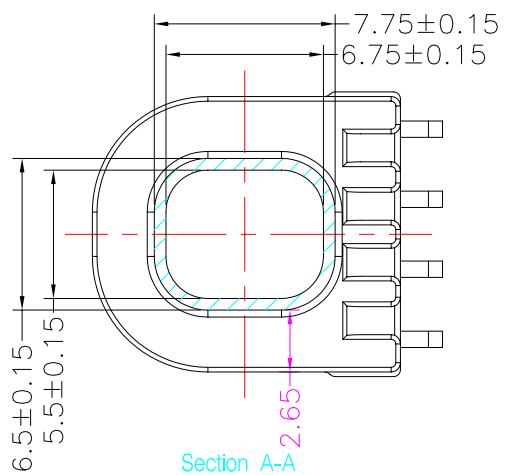

TRANSFORMER BOBBIN
INDUSTRIAL CO.,LTD.

Tel : 86-769-88789999 Fax : 86-769-88789989
http:// tbi-tw.com e-mail : tb6688@ms46.hinet.net

REVISIONS				
REV	SYM	DRAFTER	CHECKER	DATE
①		G.F.YANG	W.H.HSU	10/12/09
②		X.X.YUAN	W.H.HSU	04/25/12
③				

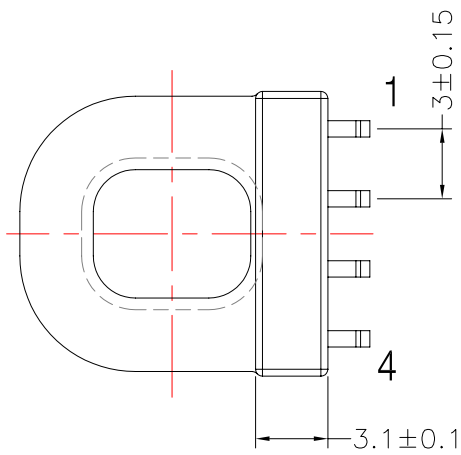
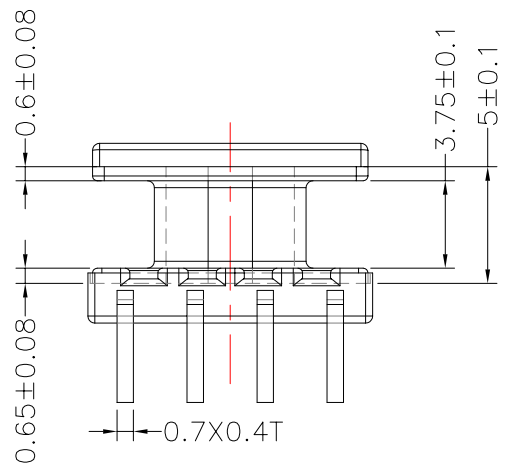
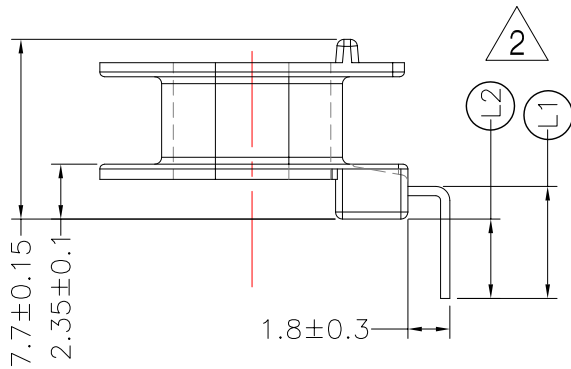
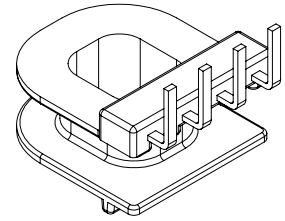
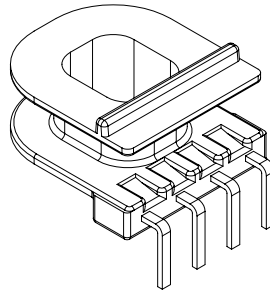
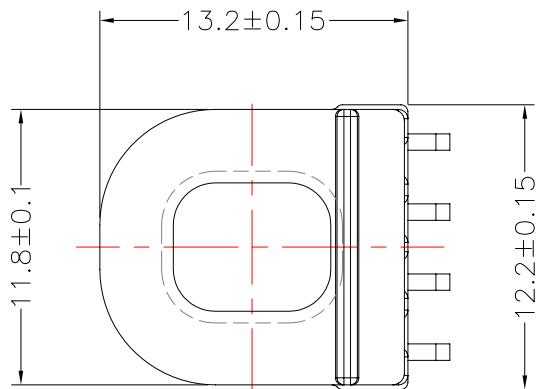

NOTE:
WINDING SPACE: 3.75mm*2.65mm=9.9375 mm²

DWG NO.	ATP15-8.3-4P-THT-0A-11				
PART NO.	MATERIAL (BOBBIN)	MATERIAL (TERMINAL)	TERMINAL (PLATING)	PIN ALLOCATION	NOTE
TBI-238-27011.1106	PM-9630	CP WIRE	Sn	ALL PIN (L1)=4.8±0.2 (L2)=3.4±0.2	S
TBI-238-27011.1116	PM-9630	CP WIRE	Sn	CUT PIN#2,4 (L1)=4.8±0.2 (L2)=3.4±0.2	H
TBI-238-27011.1126	PM-9630	CP WIRE	Sn	ALL PIN (L1)=6.0±0.2 (L2)=4.6±0.2	
TBI-238-27011.1136	PM-9630	CP WIRE	Sn	CUT PIN#1,2 (L1)=6.0±0.2 (L2)=4.6±0.2	
TBI-238-27011.1146	PM-9630	CP WIRE	Sn	ALL PIN (L1)=6.4±0.2 (L2)=5.0±0.2	
TBI-238-27011.1156	PM-9630	CP WIRE	Sn	CUT PIN#2,4 (L1)=6.0±0.2 (L2)=4.6±0.2	
	TOLERANCE: 0<L<=4:±0.1 4<L<=16:±0.2 16<L<=63:±0.3			UNIT : m / m	SCALE 1 : 1
Finish:	1. PB wire Immersion Sn on terminal : Thickness:Sn plating,100,5 μm (200 μ inches) min,Base nickel 0.625 μm (25 μ inches) min. 2. CP wire Immersion Sn on terminal : Thickness:Sn plating,100,5 μm (200 μ inches) min. 3. Coplanarity deviation: 0.10 mm (0.004 inches) max.				REV 2

A-CORE ELECTRICAL CO.

A-CORE JIANGMEN ELECTRONICS CO.,LTD
 江门安磁电子有限公司
 Tel : 86-750-3867791 Fax : 86-750-3867787

REVISIONS				
REV	SYM	DRAFTER	CHECKER	DATE
△1		G.F.YANG	W.H.HSU	10/12/09
△2				
△3				

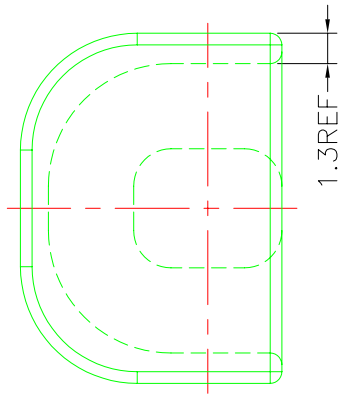
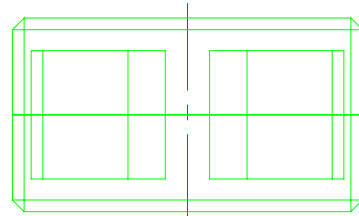
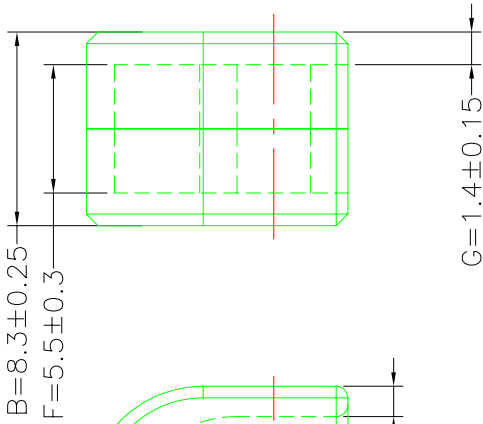
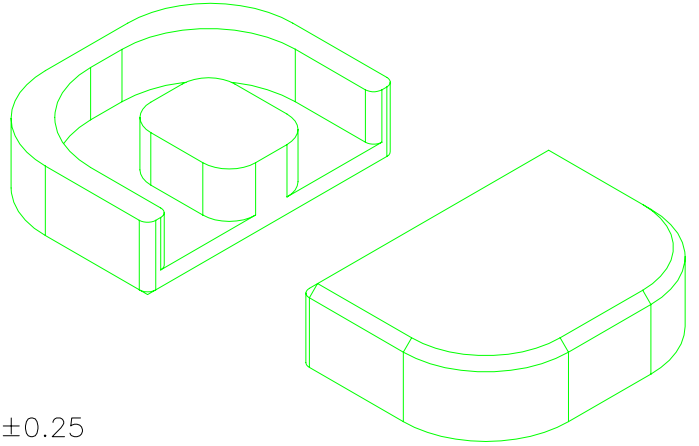
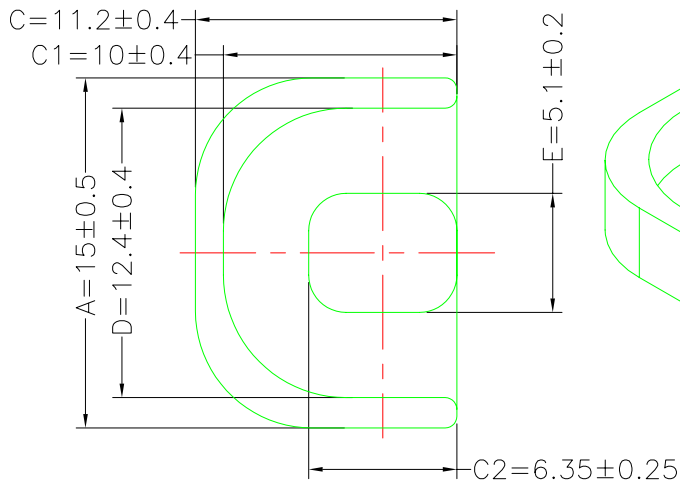

Core Set Parameters

$A_e = 33.8 \text{mm}^2$
 $L_e = 27.6 \text{mm}$
 $C_1 = 0.817 \text{mm}^{-1}$
 $V_e = 932.88 \text{mm}^3$

DWG NO.	ATP15/8.3 CORE				
PART NO.	MATERIAL (CORE)	MATERIAL (TERMINAL)	TERMINAL (PLATING)	PIN ALLOCATION	NOTE
ATP15/8.3	JPP-44A				
ATP15/8.3	JPP-95				
	TOLERANCE: 0<L<=4:±0.1 4<L<=16:±0.2 16<L<=63:±0.3			UNIT : m / m	SCALE 1 : 1

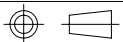

REV 1

A-CORE

A-CORE JIANGMEN ELECTRONICS CO.,LTD
江門安磁電子有限公司

TBI

TRANSFORMER BOBBIN
INDUSTRIAL CO.,LTD.

ELECTRICAL CO. Tel : 86-750-3867791 Fax : 86-750-3867787

Tel : 86-769-88789999 Fax : 86-769-88789989

e-mail : sales@acore-ferrite.com

http:// tbi-tw.com e-mail : tb6688@ms46.hinet.net

REVISIONS

REV	SYM	DRAFTER	CHECKER	DATE
△1		G.F.YANG	W.H.HSU	10/12/09
△2		X.X.YUAN	W.H.HSU	04/25/12
△3				

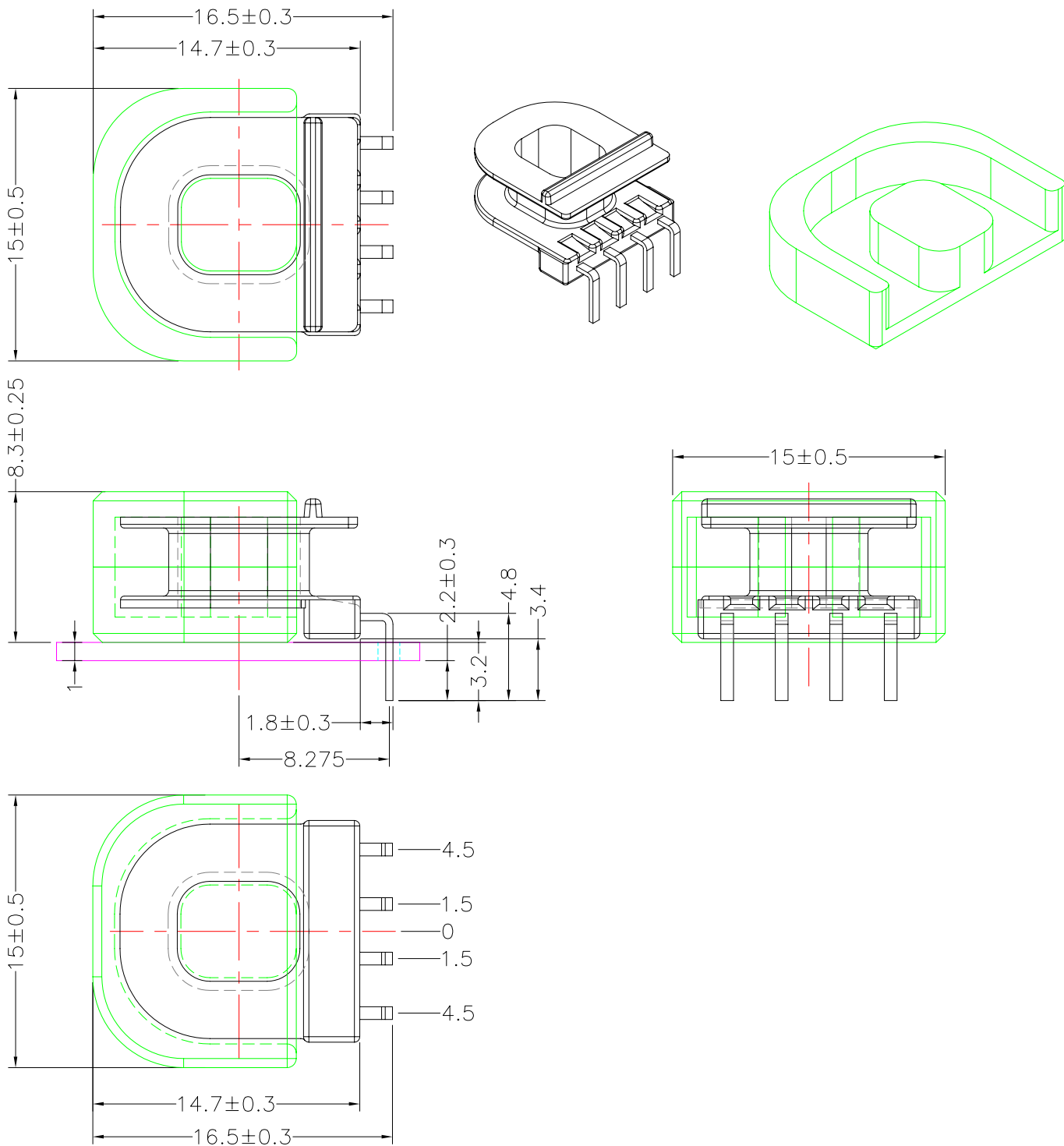

ITEM	PART NO.	MATERIAL	DWG NO.	Core Set Parameters
CORE	ATP15/8.3	JPP-44A		$A_e=33.8\text{mm}^2$ $L_e=27.6\text{mm}$ $C_1=0.817\text{mm}^{-1}$ $V_e=932.88\text{mm}^3$
CORE	ATP15/8.3	JPP-95		
BOBBIN	TBI-238-27011.11XX		ATP15-8.3-4P-THT-0A-11	
				UNIT : m/m
				SCALE 1 : 1
				REV 2