





**TRANSFORMER BOBBIN  
INDUSTRIAL CO.,LTD.**

Tel : 86-769-88789999 Fax : 86-769-88789989  
 http:// tbi-tw.com e-mail : tb6688@ms46.hinet.net

REVISIONS

REV	SYM	DRAFTER	CHECKER	DATE
△1		G.F.YANG	W.H.HSU	03/24/10
△2		X.H.GU	G.F.YANG	04/26/10
△3				

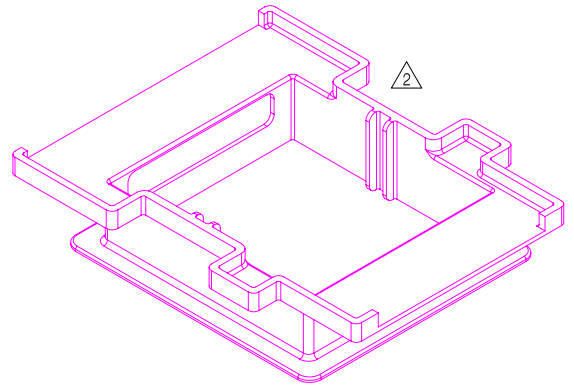
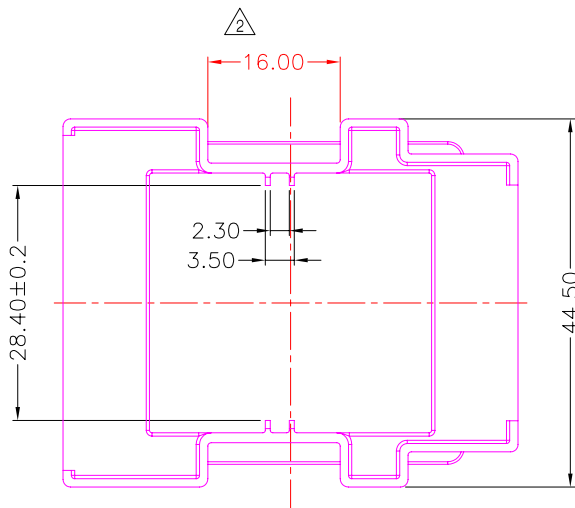
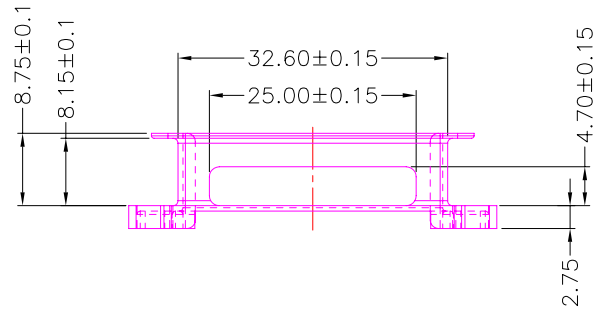
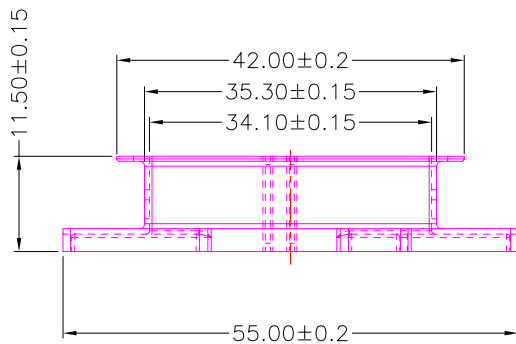
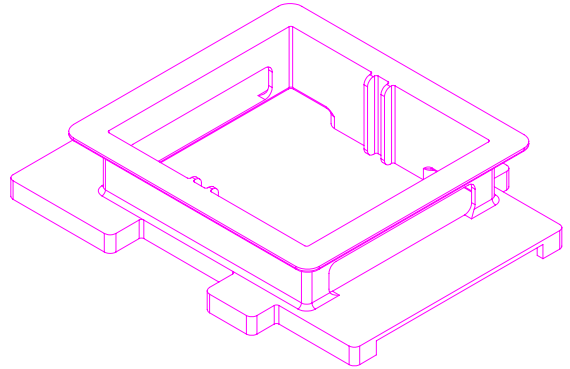
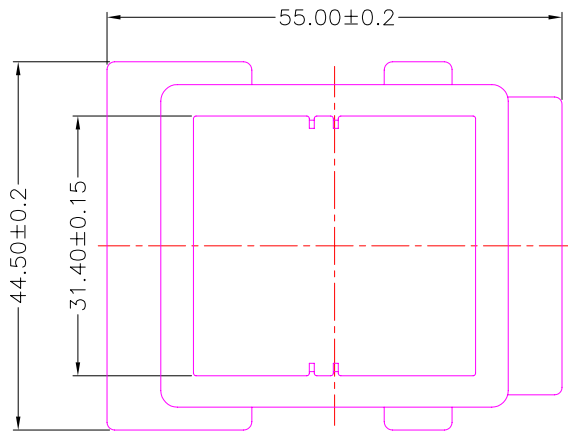

DWG NO. EFD45-49.4B-CASE-A0-91

PART NO.	MATERIAL (BOBBIN)	MATERIAL (TERMINAL)	TERMINAL (PLATING)	PIN ALLOCATION	NOTE
TBI-207-08101.91C	PET FR530 (BK)	NA	NA	NA	S H

TOLERANCE: .X±0.15 .XX±0.10 .XXX±0.05

UNIT : m / m

SCALE 1 : 1

Finish: 1. PB wire Immersion Sn on terminal : Thickness:Sn plating,100,5 μm (200 μ inches) min,Base nickel 0.625 μm (25 μ inches) min.  
 2. CP wire Immersion Sn on terminal : Thickness:Sn plating,100,5 μm (200 μ inches) min.  
 3. Coplanarity deviation: 0.10 mm (0.004 inches) max.

REV 2



**A-CORE**

A-CORE JIANGMEN ELECTRONICS CO.,LTD  
江門安磁電子有限公司

**TBI**

TRANSFORMER BOBBIN  
INDUSTRIAL CO.,LTD.

ELECTRICAL CO. Tel : 86-750-3867791 Fax : 86-750-3867787

Tel : 86-769-88789999 Fax : 86-769-88789989

e-mail : sales@acore-ferrite.com

http:// tbi-tw.com e-mail : tb6688@ms46.hinet.net

REVISIONS

REV	SYM	DRAFTER	CHECKER	DATE
△1		G.F.YANG	W.H.HSU	03/24/10
△2		X.H.GU	G.F.YANG	04/26/10
△3		X.H.GU	G.F.YANG	05/12/10

TOP

TOP

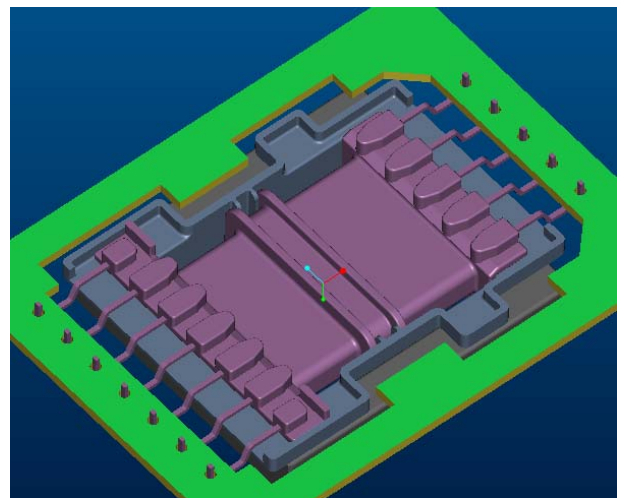
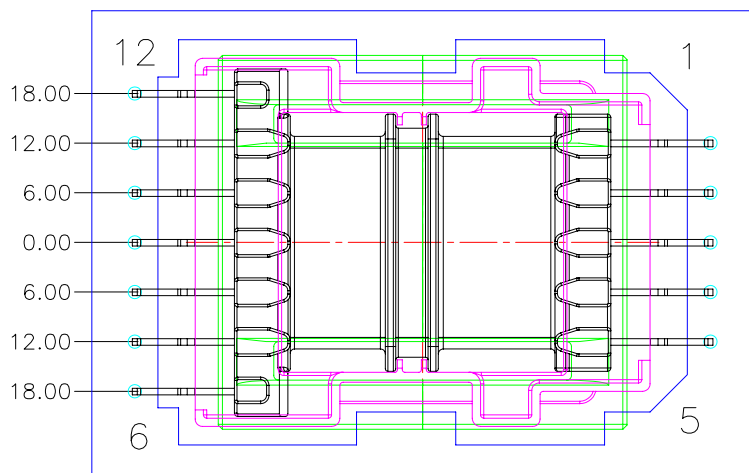
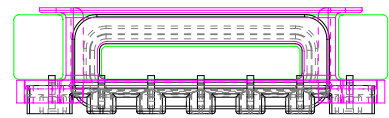
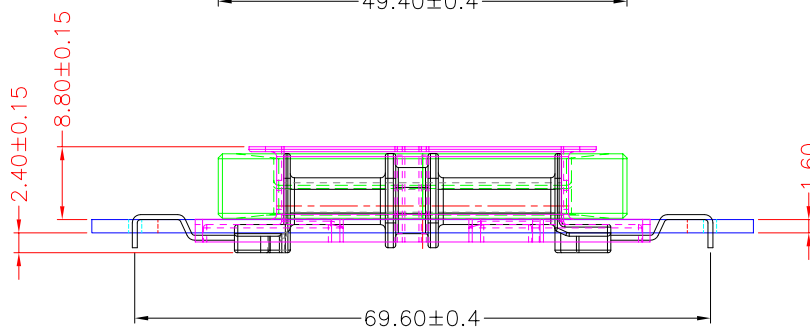
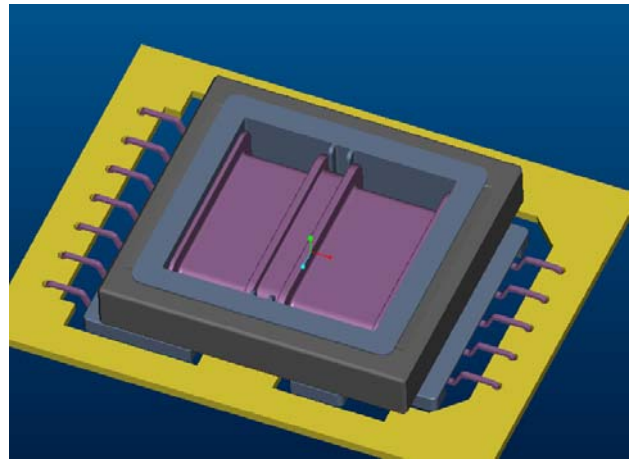
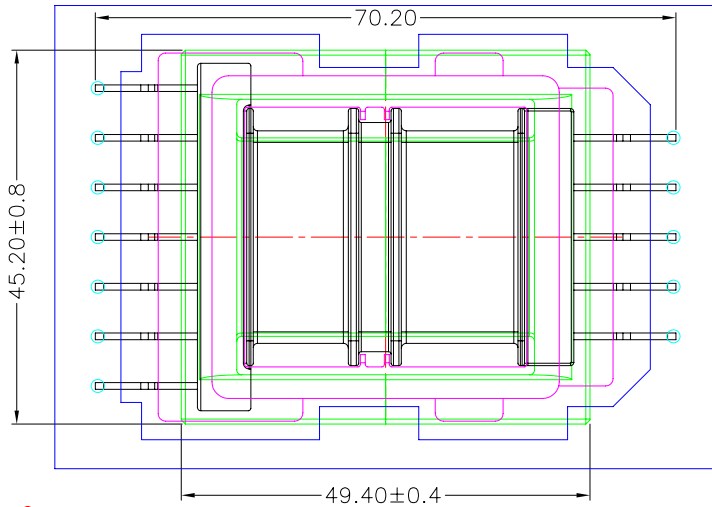

BOTTOM

BOTTOM

ITEM	PART NO.	MATERIAL	DWG NO.	Core Set Parameters
CORE	EFD45-49.4B	JPP-44A		$A_e=96.3\text{mm}^2$ $L_e=106\text{mm}$ $C_1=1.1\text{mm}^{-1}$ $V_e=10207.8\text{mm}^3$
CORE	EFD45-49.4B	JPP-95		
BOBBIN	TBI-207-08091.11XX		EFD45-49.4B-12P-THT-0J-11	
CASE	TBI-207-08101.91C		EFD45-49.4B-CASE-A0-91	

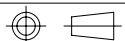

UNIT : m/m

SCALE 1 : 1

REV 3