



TRANSFORMER BOBBIN
INDUSTRIAL CO.,LTD.

Tel : 86-769-88789999 Fax : 86-769-88789989
http:// tbi-tw.com e-mail : tb6688@ms46.hinet.net

REVISIONS

REV	SYM	DRAFTER	CHECKER	DATE
△1		T.S.LII	W.H.HSU	07/13/06
△2		YAN.TANG	W.H.HSU	10/11/07
△3		YAN.TANG	G.F.YANG	03/24/08

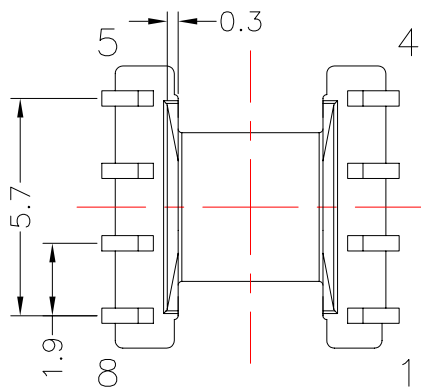
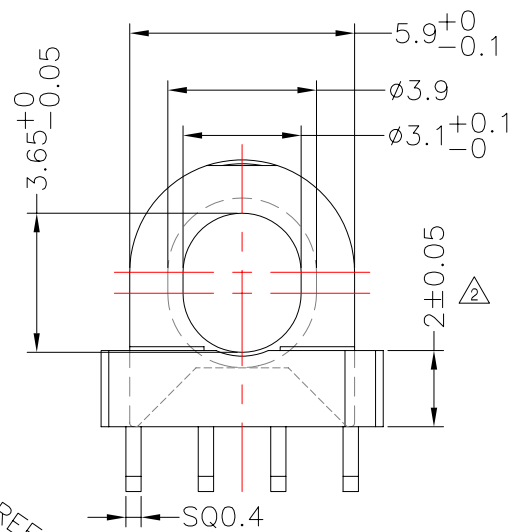
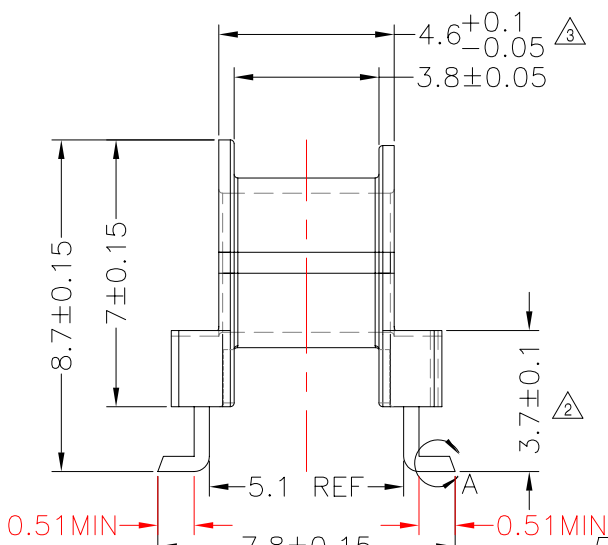
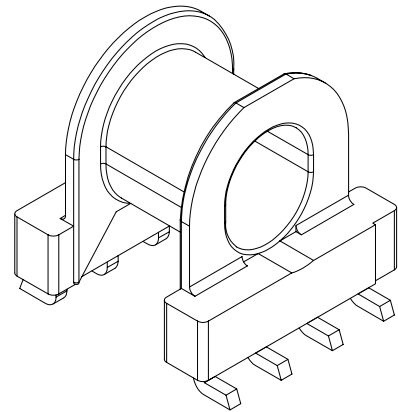
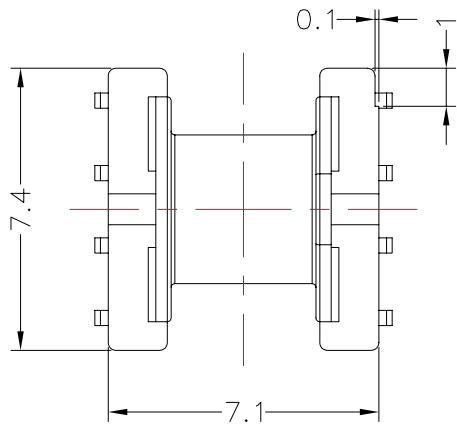

DETAIL:A
PATENTED
△ 11/02/04

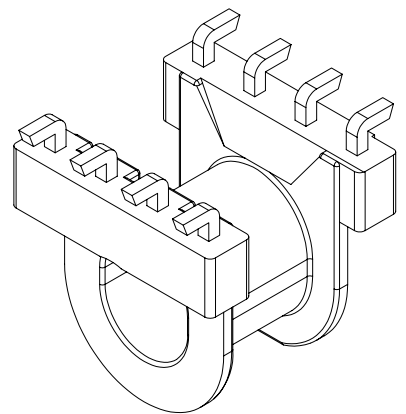
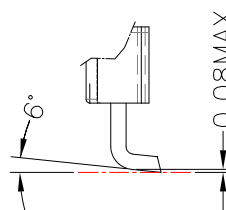

DWG NO. EPX6-8P-L-1.9-A3-1

PART NO.	MATERIAL (BOBBIN)	MATERIAL (TERMINAL)	TERMINAL (PLATING)	PIN ALLOCATION	NOTE
TBI-103-07131.103	PM-9630	PB	Sn	ALL PIN	042-2243.002

H.C

TOLERANCE: 0<L<4:±0.1 4<L<16:±0.2 16<L<63:±0.3 ANGLES:±1° UNIT : m / m SCALE 5 : 1

Finish: 1. PB wire Immersion Sn on terminal : Thickness:Sn plating,100,5 μm (200 μ inches) min,Base nickel 0.625 μm (25 μ inches) min.
2. CP wire Immersion Sn on terminal : Thickness:Sn plating,100,5 μm (200 μ inches) min.
3. Coplanarity deviation: 0.10 mm (0.004 inches) max.

REV 3