



TRANSFORMER BOBBIN
INDUSTRIAL CO.,LTD.

Tel : 86-769-88789999 Fax : 86-769-88789989
http:// tbi-tw.com e-mail : tb6888@ms46.hinet.net

REVISIONS

REV	SYM	DRAFTER	CHECKER	DATE
1		X.H.GU	G.F.YANG	07/13/16
2		X.H.GU	G.F.YANG	09/09/16
3				

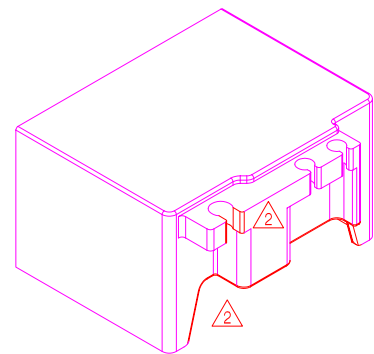
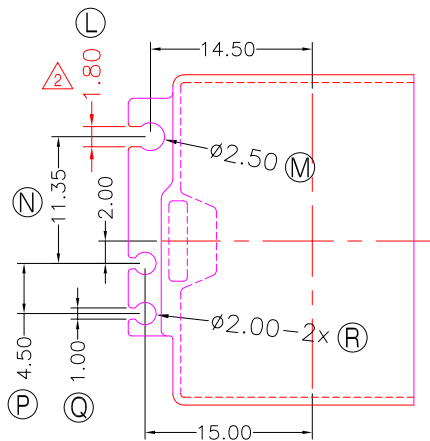
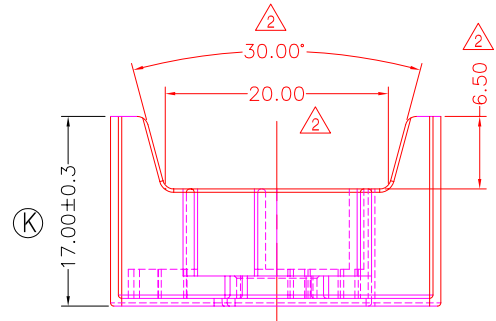
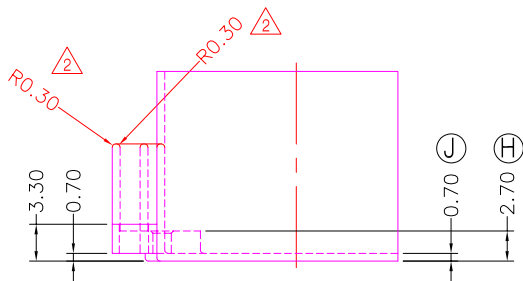
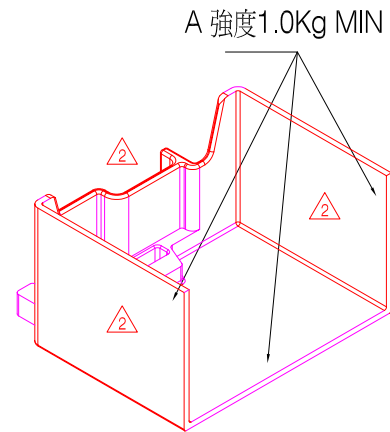
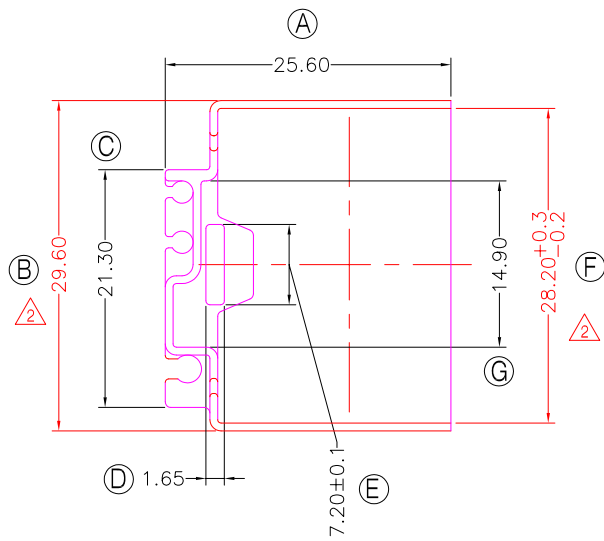

NOTE:

- 1.耐壓4.0Kv /1.5mA 60S;
- 2.任一點的強度為1.8kg MIN, 其中.A.處為1.0kg MIN
與TBI-238-48061.17XX(ATQ27-17J-5P-TH-F-17)配套使用;

DWG NO. ATQ27-17J-CASE-F-17

PART NO.	MATERIAL (BOBBIN)	MATERIAL (TERMINAL)	TERMINAL (PLATING)	PIN ALLOCATION	NOTE
TBI-238-48061.17C	PM-9823	NA			S
					H

TOLERANCE:0<L<=4:±0.1 4<L<=16:±0.2 16<L<=63:±0.3 UNIT : m / m SCALE 1 : 1

Finish: 1. PB wire Immersion Sn on terminal : Thickness:Sn plating,100%,5 μm (200 μ inches) min,Base nickel 0.625 μm (25 μ inches) min.

2. CP wire Immersion Sn on terminal : Thickness:Sn plating,100%,5 μm (200 μ inches) min.

3. Coplanarity deviation: 0.10 mm (0.004 inches) max.

REV 2