

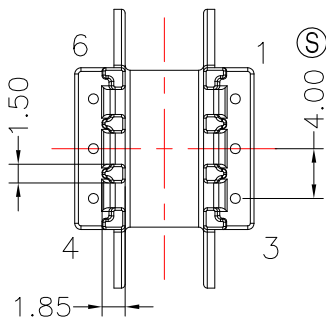

**TRANSFORMER BOBBIN
INDUSTRIAL CO.,LTD.**

Tel : 86-769-88789999 Fax : 86-769-88789989
http:// tbi-tw.com e-mail : tb6688@ms46.hinet.net

REVISIONS				
REV	SYM	DRAFTER	CHECKER	DATE
△1		X.H.GU	G.F.YANG	04/28/16
△2				
△3				

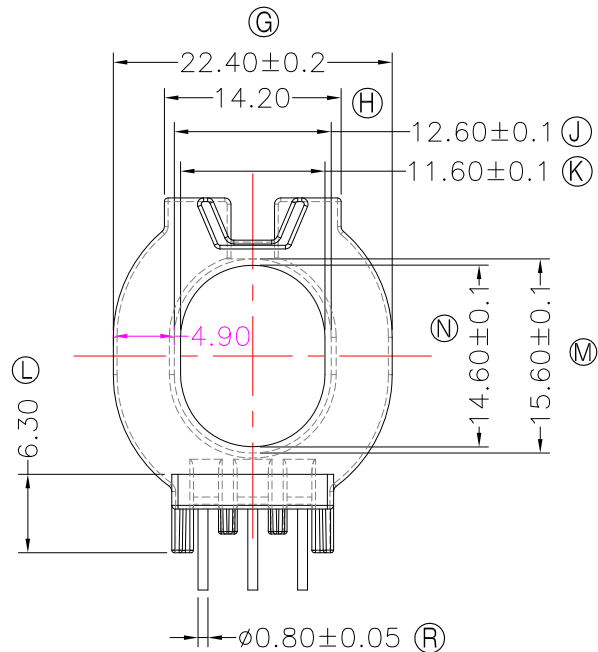
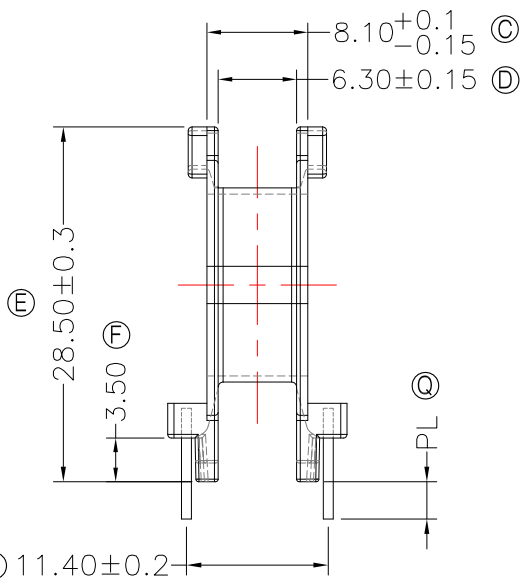
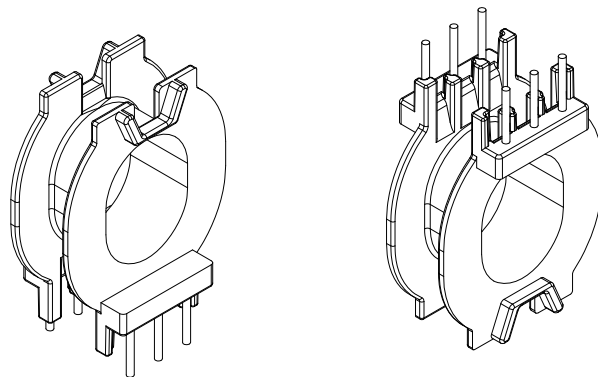
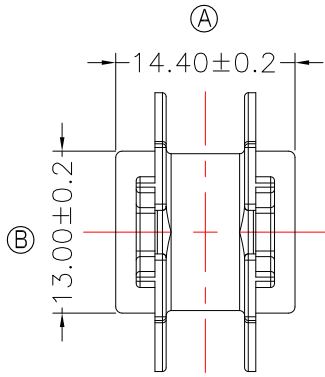

NOTE:

- 耐壓4.0Kv /1.5mA 60S;
- 焊錫溫度:450°±10° 3SEC
- 任一點的強度為1.5kg MIN;
- Winding Space=6.3*4.9=30.87mm ^ 2
- 焊錫前拉力:1.0KG MIN,焊錫後拉力:1.5KG MIN;

DWG NO.	ATQ27-14.4-6P-TH-B9-17				PIN ALLOCATION		NOTE
PART NO.	MATERIAL (BOBBIN)	MATERIAL (TERMINAL)	TERMINAL (PLATING)				
TBI-238-03291.1706	PM-9823	CP WIRE	Sn	ALL PIN	PL=3.0±0.2		H
TBI-238-03291.1716	PM-9823	CP WIRE	Sn	CUT PIN#6	PL=3.0±0.2		
TBI-238-03291.1726	PM-9823	CP WIRE	Sn	CUT PIN#5	PL=3.5±0.2		
TBI-238-03291.1736	PM-9823	CP WIRE	Sn	CUT PIN#4,5,6	PL=3.5±0.2		
TBI-238-03291.1746	PM-9823	CP WIRE	Sn	ALL PIN	PL=3.5±0.2		
TBI-238-03291.1756	PM-9823	CP WIRE	Sn	CUT PIN#2,4,5	PL=3.0±0.2		
TBI-238-03291.1766	PM-9823	CP WIRE	Sn	CUT PIN#1	PL=3.0±0.2		

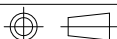

TOLERANCE: 0<L<=4: ±0.1 4<L<=16: ±0.2 16<L<=63: ±0.3

UNIT : m/m

SCALE 1:1

Finish: 1. PB wire Immersion Sn on terminal : Thickness:Sn plating,100%,5 μ m (200 μ inches) min,Base nickel 0.625 μ m (25 μ inches) min.
2. CP wire Immersion Sn on terminal : Thickness:Sn plating,100%,5 μ m (200 μ inches) min.
3. Coplanarity deviation: 0.10 mm (0.004 inches)max.

REV 1