



TRANSFORMER BOBBIN
INDUSTRIAL CO.,LTD.

Tel : 86-769-88789999 Fax : 86-769-88789999
http:// tbi-tw.com e-mail : tb6688@ms46.hinet.net

REVISIONS

REV	SYM	DRAFTER	CHECKER	DATE
1		T.S.LII	W.H.HSU	08/12/04
2		T.S.LII	W.H.HSU	09/08/04
3		T.S.LII	W.H.HSU	07/25/06

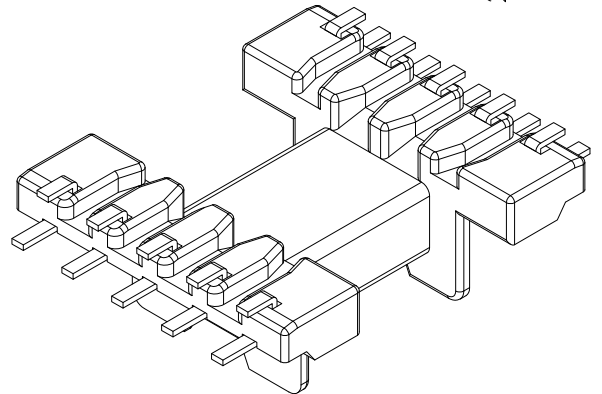
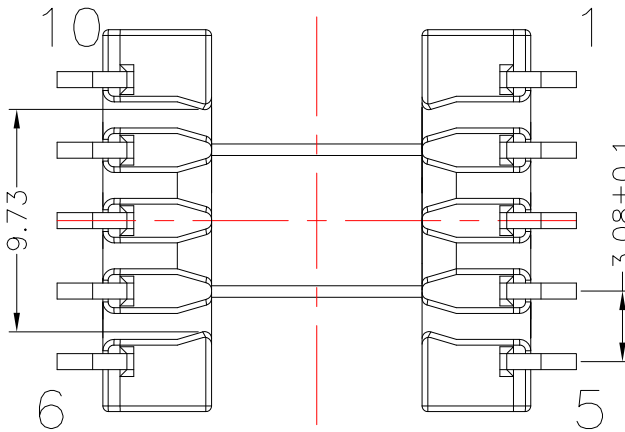
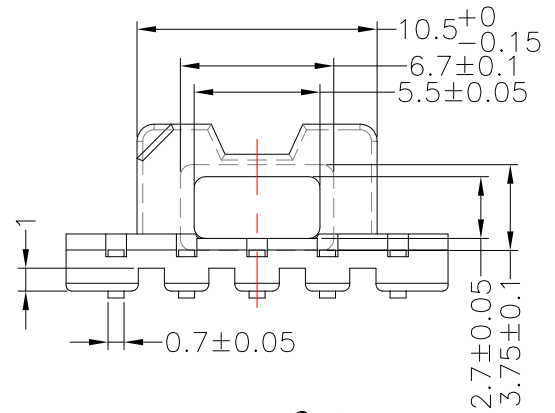
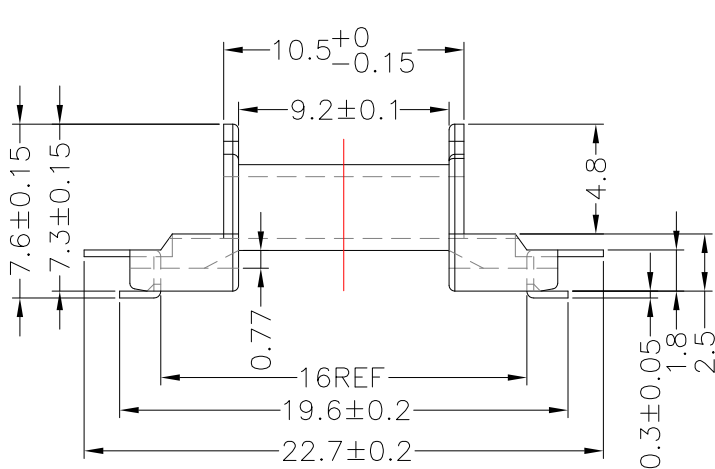
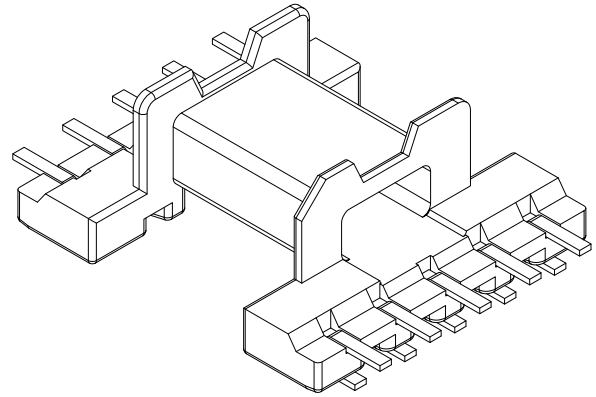
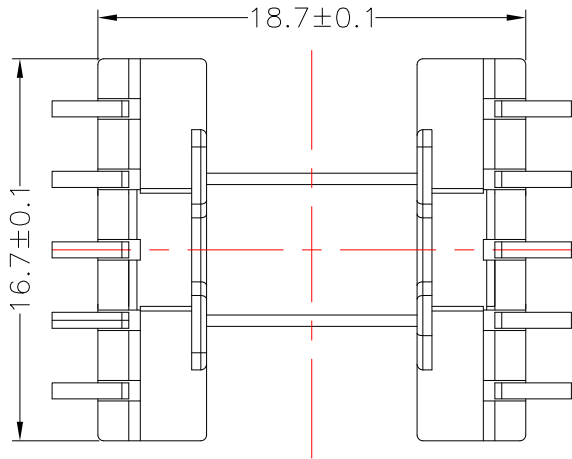

針對107-03031.113料號時, 要求Pin3不插
因產品無防呆機構, 以塑膠Pin1標示數Pin時,
生產出的產品Pin3不插或者Pin8不插都是OK可接受;

DWG NO. EFD15-10P-J-3.08-C-1

PART NO.	MATERIAL (BOBBIN)	MATERIAL (TERMINAL)	TERMINAL (PLATING)	PIN ALLOCATION	NOTE
TBI-107-03031.103	PM-9630	P.B	Sn	ALL PIN	
TBI-107-03031.113	PM-9630	P.B	Sn	CUT PIN #3	H
TBI-107-03031.126	PM-9630	C.P	Sn	ALL PIN	

TOLERANCE: .X±0.15 .XX±0.10 .XXX±0.05

UNIT : m / m

SCALE 3 : 1

Finish: 1. Pb wire Immersion Sn on terminal : Thickness:Sn plating,100,5 μ m (200 μ inches) min,Base nickel 0.625 μ m (25 μ inches) min.
2. CP wire Immersion Sn on terminal : Thickness:Sn plating,100,5 μ m (200 μ inches) min.
3. Coplanarity deviation: 0.10 mm (0.004 inches) max.

REV 3