



TRANSFORMER BOBBIN INDUSTRIAL CO.,LTD.

Tel : 86-769-88789999 Fax : 86-769-88789989
http:// tbi-tw.com e-mail : tb6688@ms46.hinet.net

REVISIONS

REV	SYM	DRAFTER	CHECKER	DATE
△1		X.H.GU	G.F.YANG	11/11/21
△2				
△3				

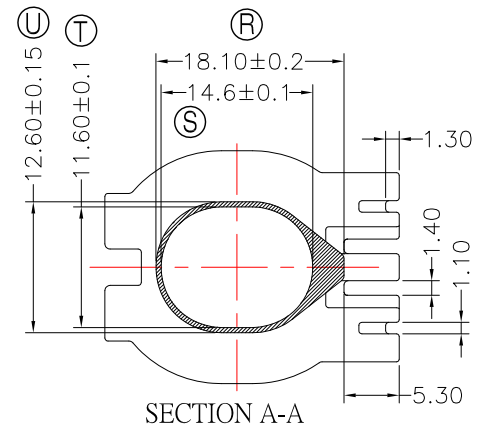
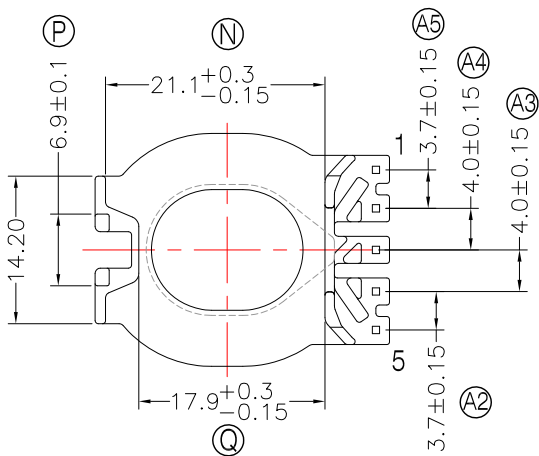
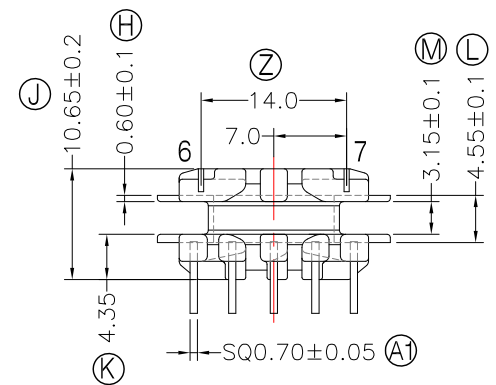
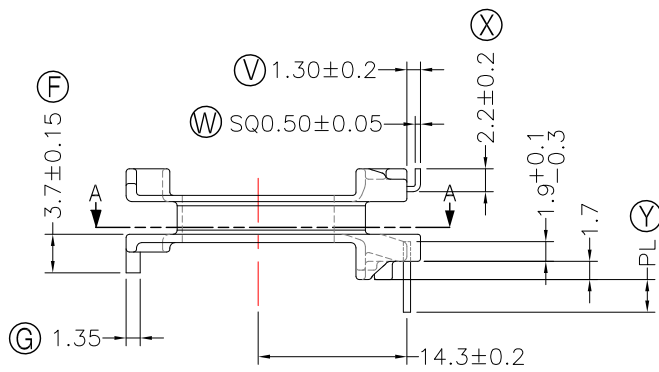
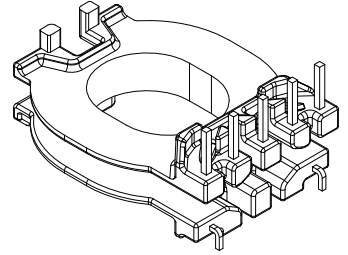
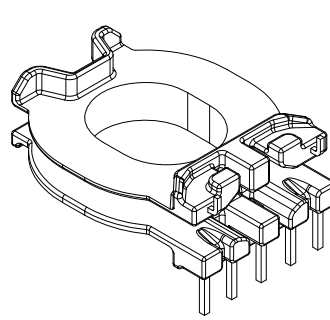
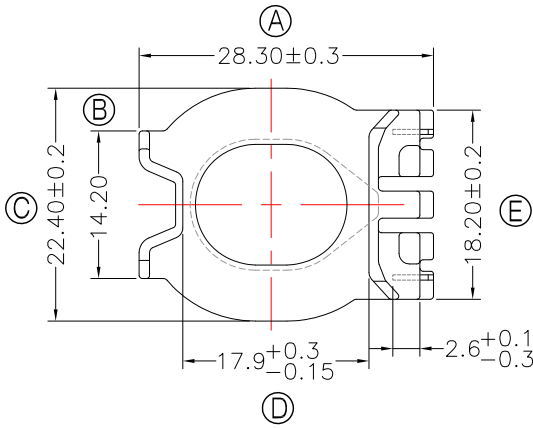

NOTE:

- 1.耐壓4.0Kv /1.5mA 60S;
- 2.焊錫溫度:450°±10° 3SEC
- 3.任一點的強度為1.5kg MIN;
- 4.焊錫前拉力:1.0KG MIN,焊錫後拉力:1.5KG MIN;

與TBI-238-48291.11C(ATQ27-10.2N-CASE-B9-11)配套使用;

DWG NO.	ATQ27-10.2N-7P-TH-B9-11				
PART NO.	MATERIAL (BOBBIN)	MATERIAL (TERMINAL)	TERMINAL (PLATING)	PIN ALLOCATION	NOTE
TBI-238-48291.1106	PM-9630	CP WIRE	Sn	ALL PIN PL=5.0±0.2	S
					H
TOLERANCE: 0<L<=4:±0.1 4<L<=16:±0.2 16<L<=63:±0.3				UNIT : m / m	SCALE 1 : 1

Finish: 1. PB wire Immersion Sn on terminal : Thickness:Sn plating,100%,5 μm (200 μ inches) min,Base nickel 0.625 μm (25 μ inches) min.

2. CP wire Immersion Sn on terminal : Thickness:Sn plating,100%,5 μm (200 μ inches) min.

3. Coplanarity deviation: 0.10 mm (0.004 inches) max.

REV 1