



**TRANSFORMER BOBBIN INDUSTRIAL CO.,LTD.**

Tel : 86-769-88789999 Fax : 86-769-88789999  
 http:// tbi-tw.com e-mail : tb6688@ms46.hinet.net

REVISIONS

REV	SYM	DRAFTER	CHECKER	DATE
①		X.H.GU	G.F.YANG	11/25/16
②		X.H.GU	G.F.YANG	12/23/16
③				

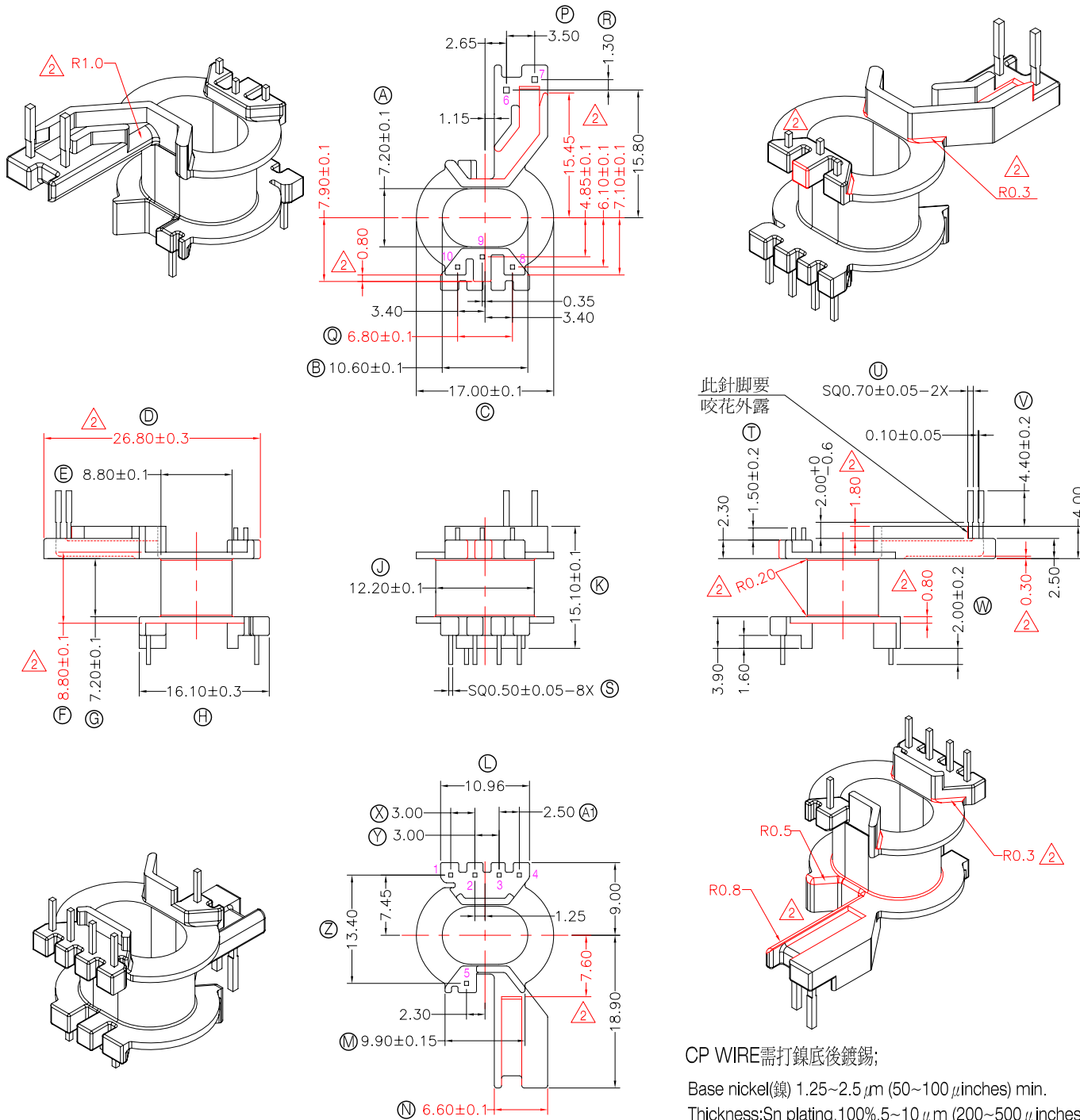

DWG NO.	PQ20-10P-TH-F-11			PIN ALLOCATION	NOTE
PART NO.	MATERIAL (BOBBIN)	MATERIAL (TERMINAL)	TERMINAL (PLATING)	ALL PIN	H.C
TBI-216-01061.1106	PM-9630	CP WIRE	Sn		
TOLERANCE: 0<L<=4:±0.1 4<L<=10:±0.2				UNIT : m / m	SCALE 1 : 1

Finish: 1. PB wire Immersion Sn on terminal : Thickness:Sn plating,100%,5 μm (200 μinches) min,Base nickel 0.625 μm (25 μ inches) min.  
 2. CP wire Immersion Sn on terminal : Thickness:Sn plating,100%,5 μm (200 μinches) min.  
 3. Coplanarity deviation: 0.10 mm (0.004 inches) max.

REV 2