

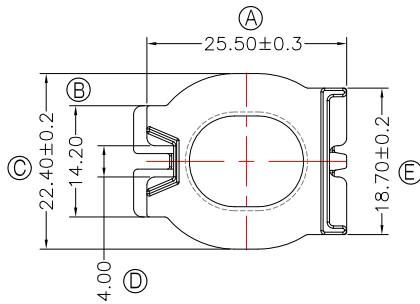

TRANSFORMER BOBBIN
INDUSTRIAL CO.,LTD.

Tel : 86-769-88789999 Fax : 86-769-88789989
http:// tbi-tw.com e-mail : tb6688@ms46.hinet.net

REVISIONS				
REV	SYM	DRAFTER	CHECKER	DATE
△		M.WANG	G.F.YANG	07/28/16
△				
△				



A 強度1.3Kg MIN

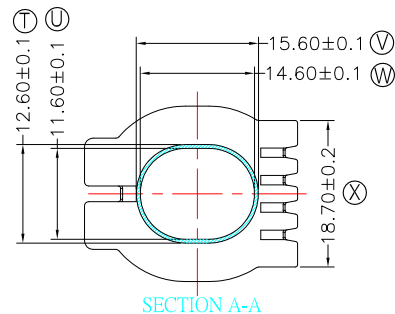
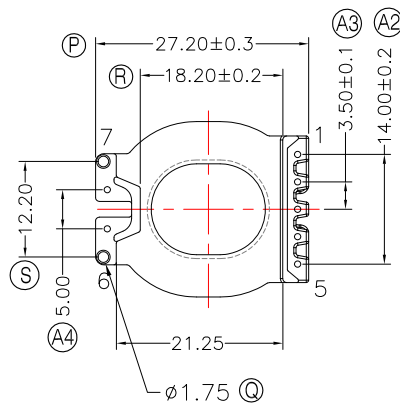
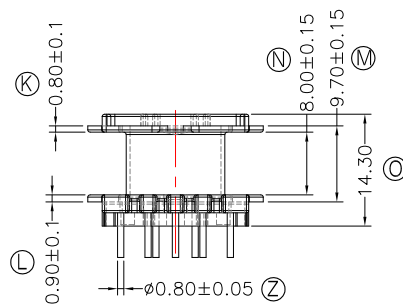
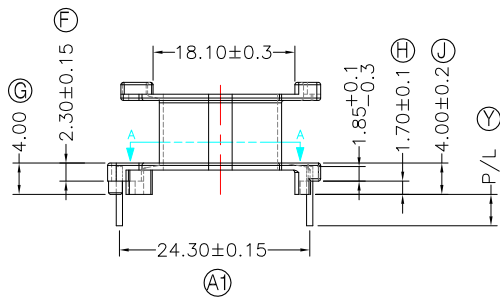
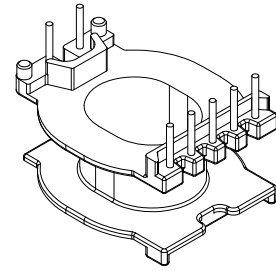
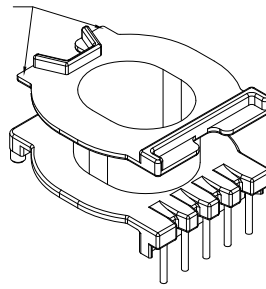

NOTE:

- 1.耐壓4.0Kv /1.5mA 60S;
- 2.焊錫溫度:450°±10° 3SEC
- 3.焊錫前拉力:1.0KG MIN,焊錫後拉力:1.5KG MIN;
- 4.任一點的強度為1.8kg MIN;其中頂部A處為1.3kg MIN;

DWG NO. ATQ27-16-1-7P-TH-D7-17

PART NO.	MATERIAL (BOBBIN)	MATERIAL (TERMINAL)	TERMINAL (PLATING)	PIN ALLOCATION	NOTE
TBI-238-03471.1706	PM-9823	CP WIRE	Sn	ALL PIN P/L= 4.0±0.2	用于PFC S
TBI-238-03471.1716	PM-9823	CP WIRE	Sn	NO PIN#3 P/L=4.0±0.2	H
TBI-238-03471.1726	PM-9823	CP WIRE	Sn	NO PIN#1,2,6 P/L=5.0±0.2	
TBI-238-03471.1736	PM-9823	CP WIRE	Sn	NO PIN#6,7 P/L=4.0±0.2	
TBI-238-03471.1746	PM-9823	CP WIRE	Sn	NO PIN#1,2,6 P/L=3.1±0.2	
TBI-238-03471.1756	PM-9823	CP WIRE	Sn	NO PIN#2,4,6 P/L=4.0±0.2	
TBI-238-03471.1766	PM-9823	CP WIRE	Sn	NO PIN#3,7 P/L=4.0±0.2	
TBI-238-03471.1776	PM-9823	CP WIRE	Sn	NO PIN#2,5 P/L=4.0±0.2	
TBI-238-03471.1786	PM-9823	CP WIRE	Sn	NO PIN#4,7 P/L=4.0±0.2	
TBI-238-03471.1796	PM-9823	CP WIRE	Sn	ALL PIN P/L=5.0±0.2	
TBI-238-03471.17A6	PM-9823	CP WIRE	Sn	NO PIN#2,6,7 P/L=4.0±0.2	
TBI-238-03471.17B6	PM-9823	CP WIRE	Sn	NO PIN#1,3 P/L=3.5±0.2	
TBI-238-03471.17C6	PM-9823	CP WIRE	Sn	NO PIN#1,3 P/L=4.0±0.2	
TBI-238-03471.17D6	PM-9823	CP WIRE	Sn	NO PIN#3 P/L=4.3±0.2	
TBI-238-03471.17E6	PM-9823	CP WIRE	Sn	NO PIN#2 P/L=3.5±0.2	

TOLERANCE: 0<L≤4±0.1 4<L≤16±0.2 16<L≤63±0.3 UNIT : m/m SCALE 1:1

Finish: 1. PB wire Immersion Sn on terminal : Thickness:Sn plating,100%,5 μm (200 μinches) min,Base nickel 0.625 μm (25 μinches) min.
2. CP wire Immersion Sn on terminal : Thickness:Sn plating,100%,5 μm (200 μinches) min.
3. Coplanarity deviation: 0.10 mm (0.004 inches) max.

REV 1