

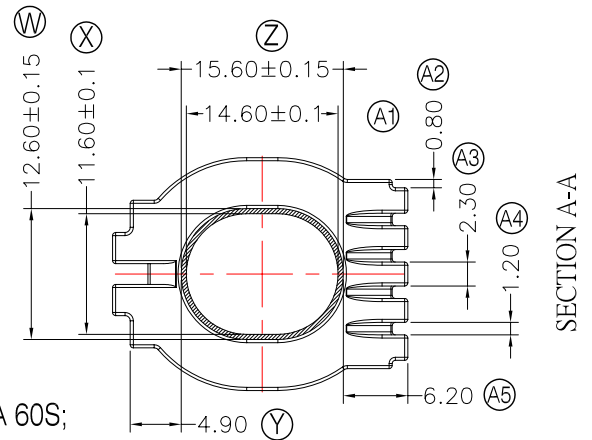

TRANSFORMER BOBBIN  
INDUSTRIAL CO.,LTD.

Tel : 86-769-88789999 Fax : 86-769-88789989  
http:// tbi-tw.com e-mail : tb6688@ms46.hinet.net

REVISIONS				
REV	SYM	DRAFTER	CHECKER	DATE
1		X.H.GU	G.F.YANG	11/19/19
2				
3				

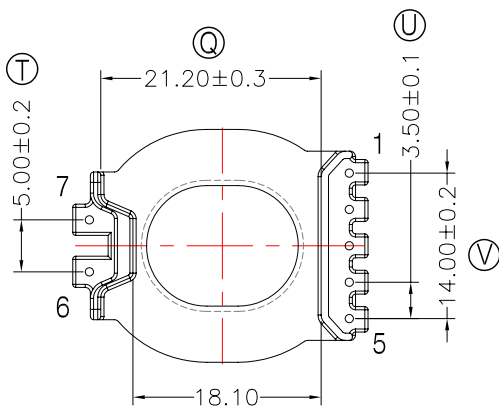
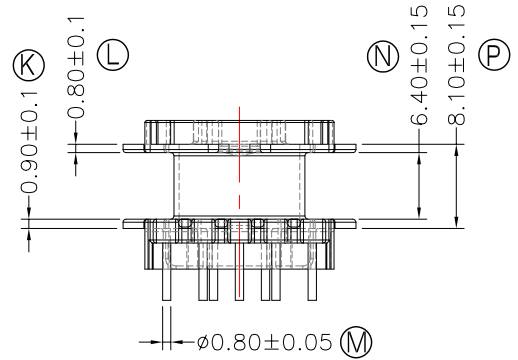
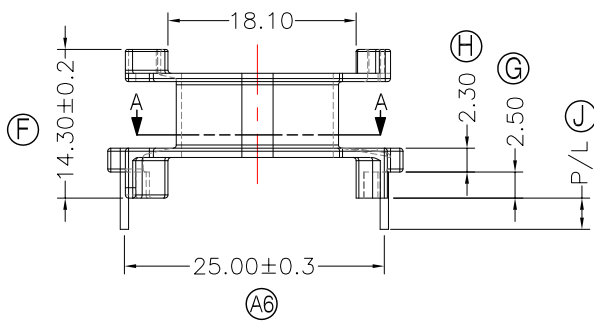
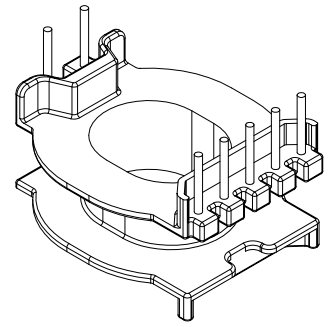
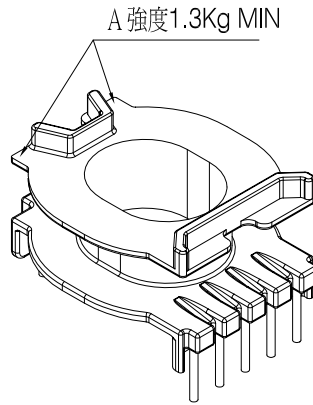
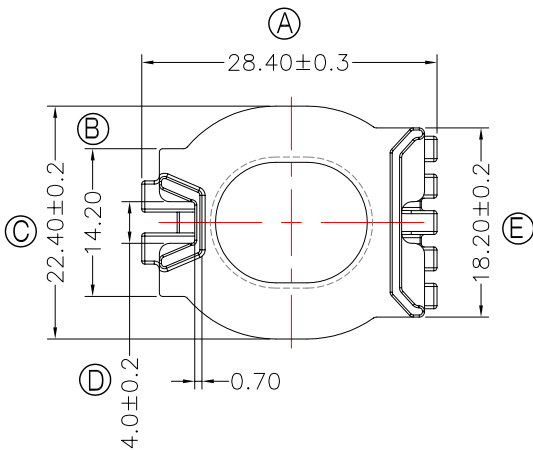

- NOTE:
- 1.耐壓4.0Kv /1.5mA 60S;
  - 2.焊錫溫度:450°±10° 3SEC
  - 3.焊錫前拉力:1.0KG MIN,焊錫後拉力:1.5KG MIN;
  - 4.任一點的強度為1.8kg MIN;其中頂部A處為1.3kg MIN;
  - 5.Winding Space=6.4\*4.9=31.36mm ^ 2

DWG NO. ATQ27-14.4-7P-TH-B2-11

PART NO.	MATERIAL (BOBBIN)	MATERIAL (TERMINAL)	TERMINAL (PLATING)	PIN ALLOCATION	NOTE
TBI-238-48221.1106	PM-9630	CP WIRE	Sn	ALL PIN P/L=5.0±0.2	H
TBI-238-48221.1116	PM-9630	CP WIRE	Sn	CUT PIN#2 P/L=3.5±0.2	
TBI-238-48221.1126	PM-9630	CP WIRE	Sn	CUT PIN#2 P/L=5.0±0.2	
TBI-238-48221.1136	PM-9630	CP WIRE	Sn	CUT PIN#2 P/L=3.2±0.2	

TOLERANCE: 0<L<=4:±0.1 4<L<=16:±0.2 16<L<=63:±0.3

UNIT : m / m

SCALE 1 : 1

Finish: 1. PB wire Immersion Sn on terminal : Thickness:Sn plating,100%,5 μm (200 μ inches) min,Base nickel 0.625 μm (25 μ inches) min.  
2. CP wire Immersion Sn on terminal : Thickness:Sn plating,100%,5 μm (200 μ inches) min.  
3. Coplanarity deviation: 0.10 mm (0.004 inches) max.

REV 1

**A-CORE**  
ELECTRICAL CO.

A-CORE JIANGMEN ELECTRONICS CO.,LTD  
 江门安磁电子有限公司  
 Tel: 86-750-3867791 Fax : 86-750-3867787

REVISIONS

REV	SYM	DRAFTER	CHECKER	DATE
1		G.F.YANG	W.H.HSU	10/12/09
2				
3				

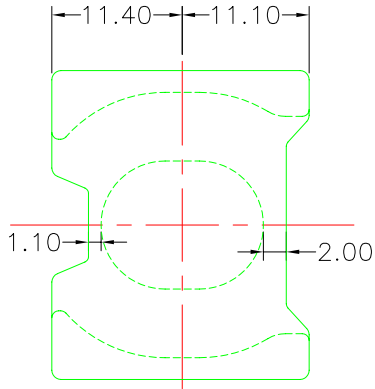
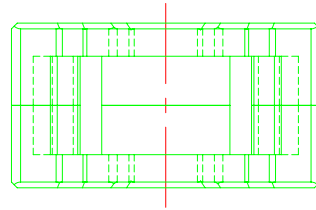
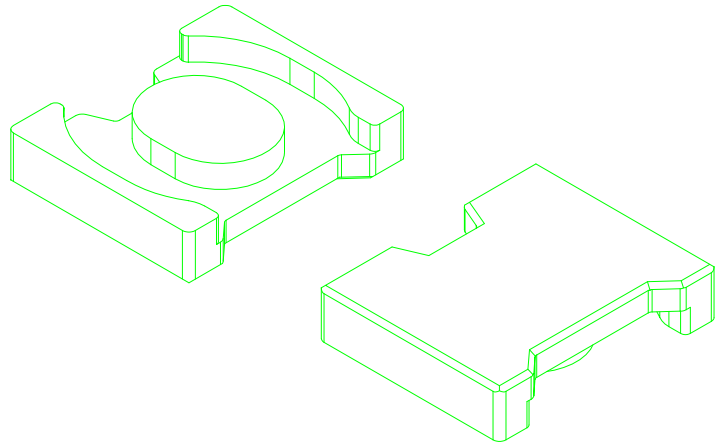
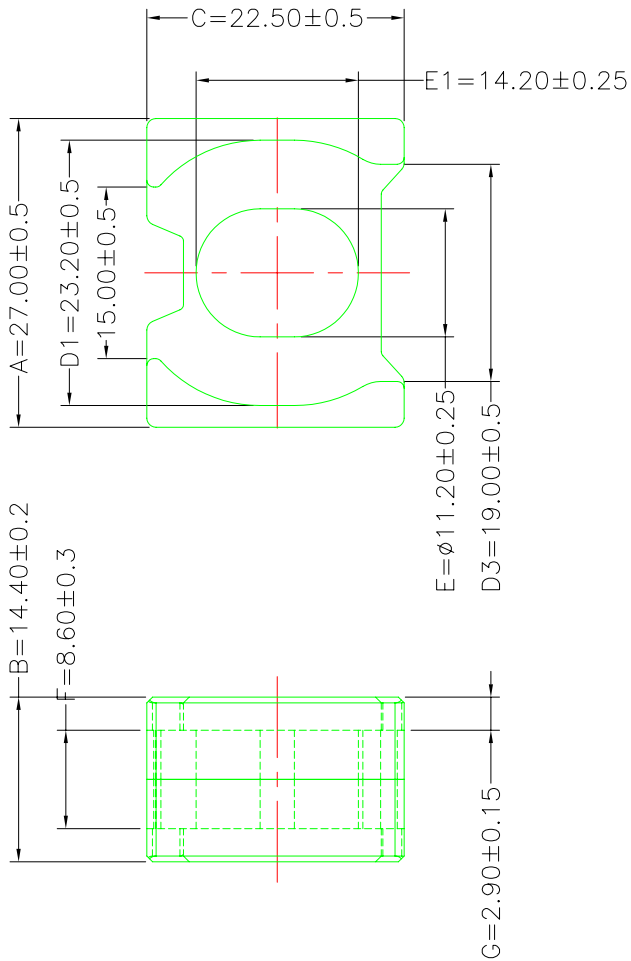

Core Set Parameters

Ae=131.5mm<sup>2</sup>  
 Le=43mm  
 C1=0.327mm<sup>-1</sup>  
 Ve=5654.5mm<sup>3</sup>

DWG NO.	ATQ27/14.4-CORE			NOTE
PART NO.	MATERIAL (CORE)			
ATQ27/14.4	JPP-44A			
ATQ27/14.4	JPP-95			

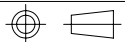

TOLERANCE: 0<L<=4:±0.1 4<L<=16:±0.2 16<L<=63:±0.3

UNIT : m / m

SCALE 1 : 1

REV 1

**A-CORE**

A-CORE JIANGMEN ELECTRONICS CO.,LTD  
江門安磁電子有限公司

**TBI**

TRANSFORMER BOBBIN  
INDUSTRIAL CO.,LTD.

ELECTRICAL CO. Tel : 86-750-3867791 Fax : 86-750-3867787

Tel : 86-769-88789999 Fax : 86-769-88789989

e-mail : sales@acore-ferrite.com

http:// tbi-tw.com e-mail : tb6688@ms46.hinet.net

REVISIONS

REV	SYM	DRAFTER	CHECKER	DATE
△1		X.H.GU	G.F.YANG	11/19/19
△2				
△3				

TOP

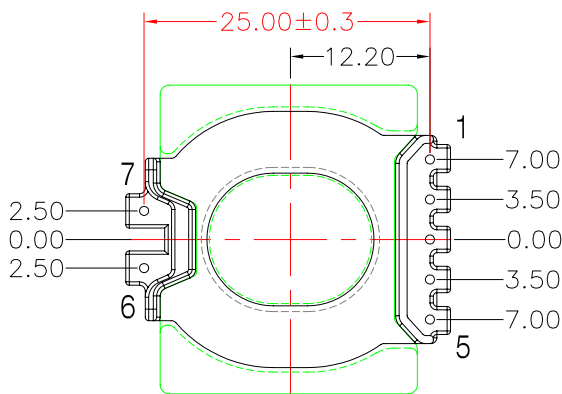
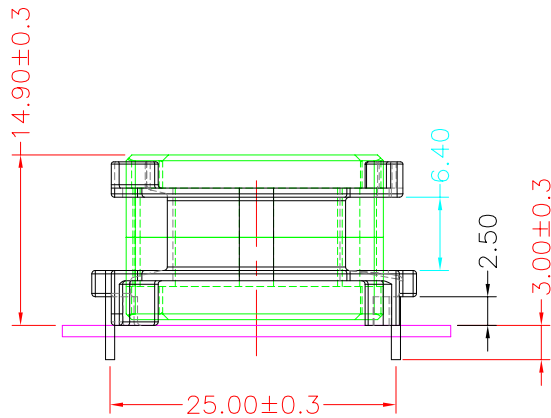
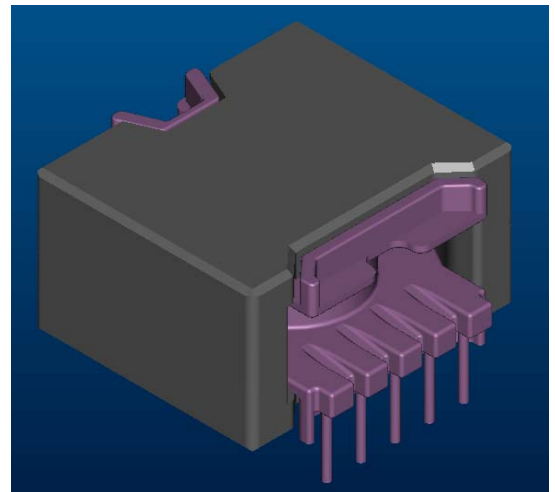
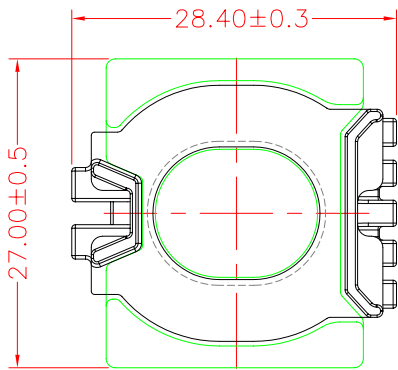

BOTTOM

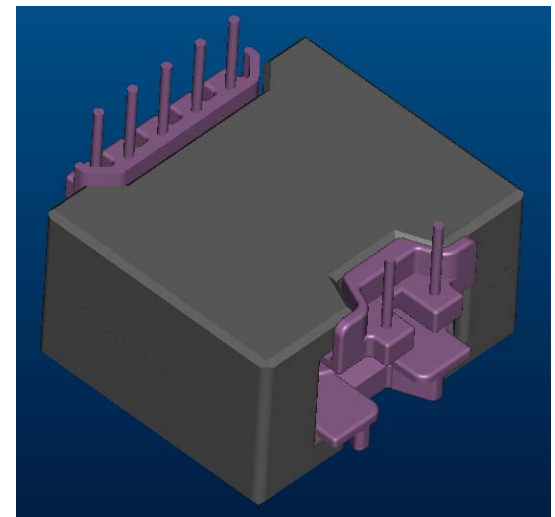

ITEM	PART NO.	MATERIAL	DWG NO.	Core Set Parameters
CORE	ATQ27-14.4	JPP-44A		Ae=131.5mm <sup>2</sup> Le=43mm C1=0.327mm <sup>-1</sup> Ve=5654.5mm <sup>3</sup>
CORE	ATQ27-14.4	JPP-95		
BOBBIN	TBI-238-48221.11XX		ATQ27-14.4-7P-TH-B2-11	

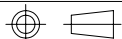

UNIT : m/m

SCALE 1 : 1

REV 1