

A-CORE

A-CORE JIANGMEN ELECTRONICS CO.,LTD
 江門安磁電子有限公司

TBI

TRANSFORMER BOBBIN
 INDUSTRIAL CO.,LTD.

ELECTRICAL CO. Tel : 86-750-3867791 Fax : 86-750-3867787

Tel : 86-769-88789999 Fax : 86-769-88789989

e-mail : sales@acore-ferrite.com

http:// tbi-tw.com e-mail : tb6688@ms46.hinet.net

REVISIONS

REV	SYM	DRAFTER	CHECKER	DATE
△2		X.H.GU	G.F.YANG	10/21/10
△3		G.F.YANG	W.H.HSU	12/09/10
△4		G.F.YANG	W.H.HSU	01/06/11

TOP

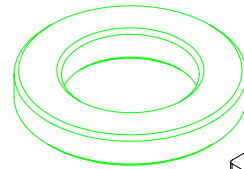
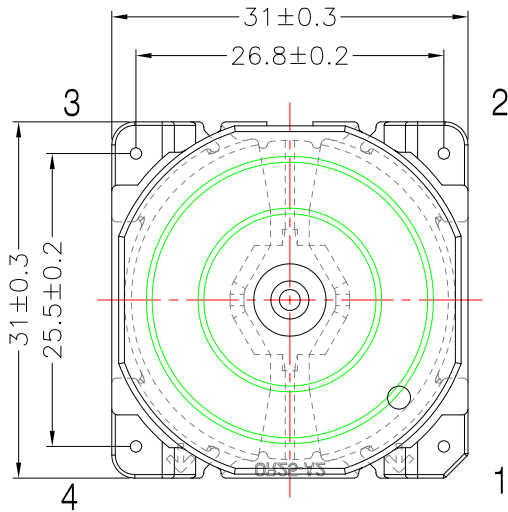

TOP

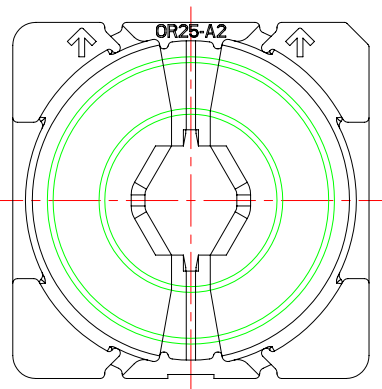
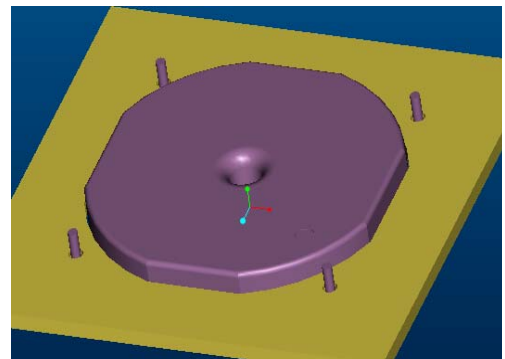
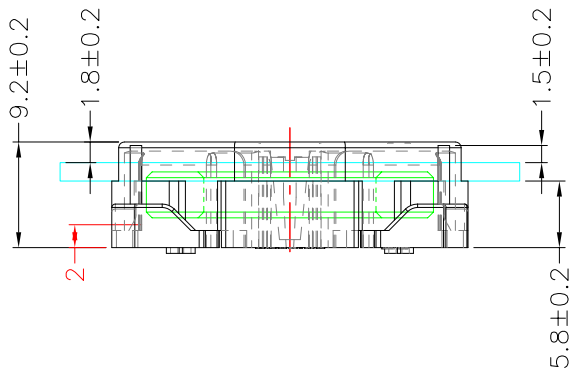
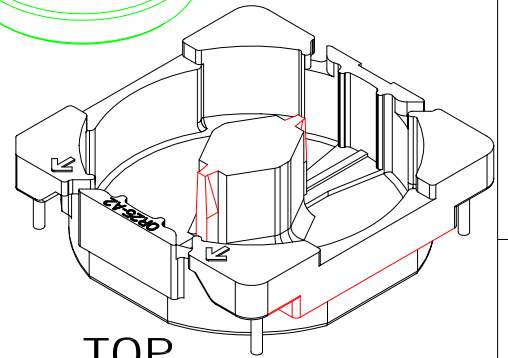

BOTTOM

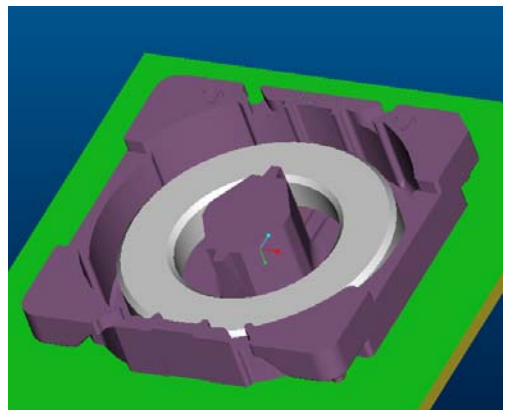

BOTTOM

ITEM	PART NO.	MATERIAL	DWG NO.	Core Set Parameters
CORE	OR25X4-15	JPH-10F		Ae=19.6mm ² Le=60.2mm C1=3.08mm ⁻¹ Ve=1179.92mm ³
BASE	TBI-220-16121.12XX		OR25X4-15-BASE-A2-12	
CAP	TBI-220-16061.51		OR25X4-15-CAP-F-51	

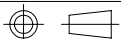

UNIT : m / m

SCALE 1 : 1

REV 4