



**TRANSFORMER BOBBIN
INDUSTRIAL CO.,LTD.**

Tel : 86-769-88789999 Fax : 86-769-88789989
 http:// tbi-tw.com e-mail : tb6688@ms46.hinet.net

REVISIONS

REV	SYM	DRAFTER	CHECKER	DATE
1		S.Y.TANG	G.F.YANG	12/18/07
2		S.Y.TANG	G.F.YANG	12/18/07
3				

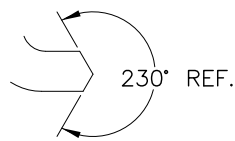
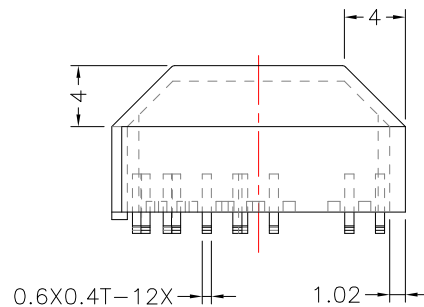
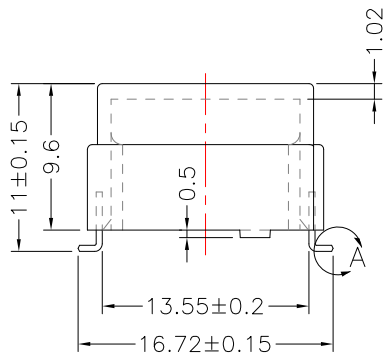
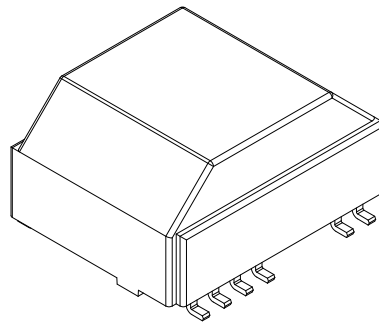
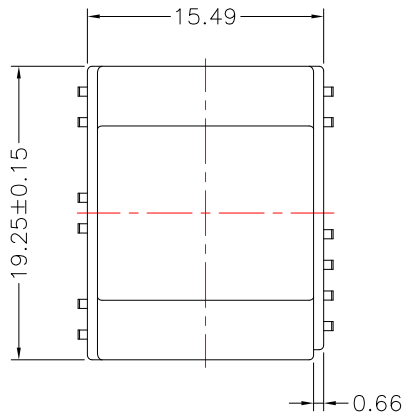

DETAIL:A
PATENTED

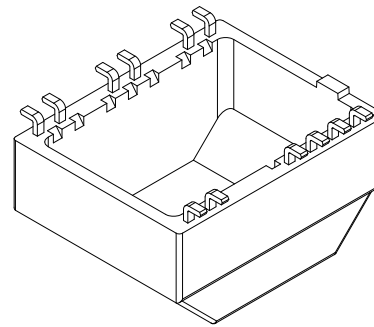
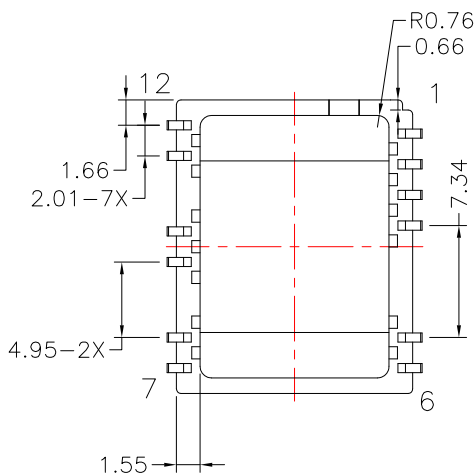

DWG NO. H0904-12P-L-G-11

PART NO.	MATERIAL (BOBBIN)	MATERIAL (TERMINAL)	TERMINAL (PLATING)	PIN ALLOCATION	NOTE
TBI-113-10071.1103	PM-9630	P.B	Sn	ALL PIN	

TBI-113-10071.1103

PM-9630

P.B

Sn

ALL PIN

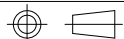

TOLERANCE: ±0.1

UNIT : m / m

SCALE 2 : 1

Finish: 1. Pb wire Immersion Sn on terminal : Thickness:Sn plating,100,5 μm (200 μ inches) min,Base nickel 0.625 μm (25 μ inches) min.
 2. CP wire Immersion Sn on terminal : Thickness:Sn plating,100,5 μm (200 μ inches) min.
 3. Coplanarity deviation: 0.10 mm (0.004 inches) max.

REV 2