





**A-CORE**A-CORE JIANGMEN ELECTRONICS CO.,LTD  
江門安磁電子有限公司**TBI**TRANSFORMER BOBBIN  
INDUSTRIAL CO.,LTD.

ELECTRICAL CO. Tel : 86-750-3867791 Fax : 86-750-3867787

Tel : 86-769-88789999 Fax : 86-769-88789989

e-mail : sales@acore-ferrite.com

http:// tbi-tw.com e-mail : tb6688@ms46.hinet.net

## REVISIONS

REV	SYM	DRAFTER	CHECKER	DATE
△1		G.F.YANG	W.H.HSU	11/07/09
△2				
△3				

TOP

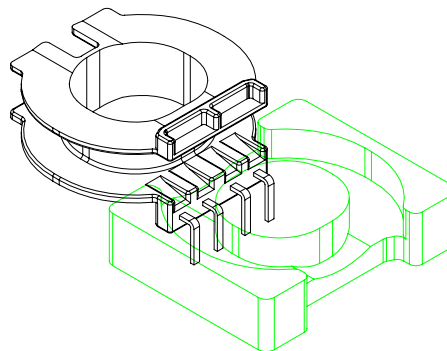
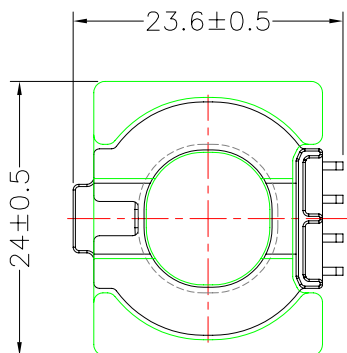

TOP

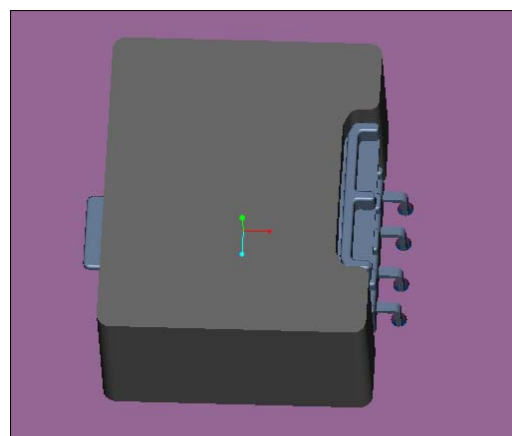
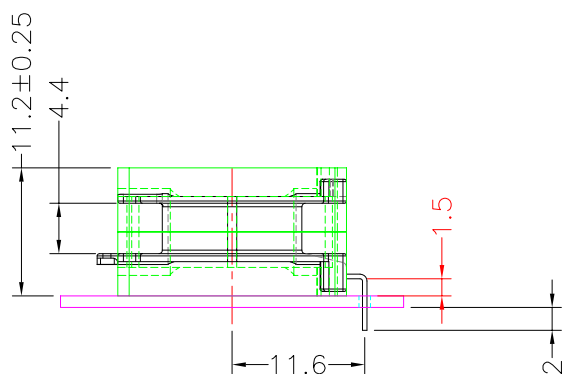

BOTTOM

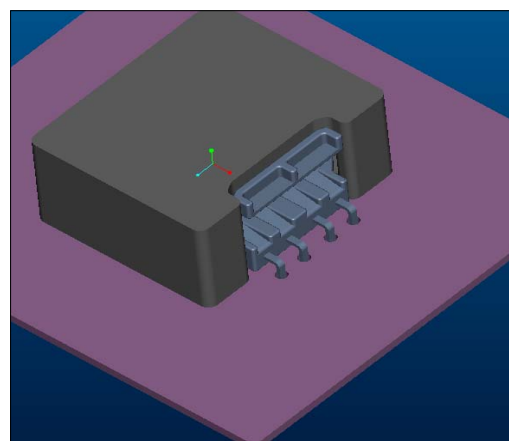
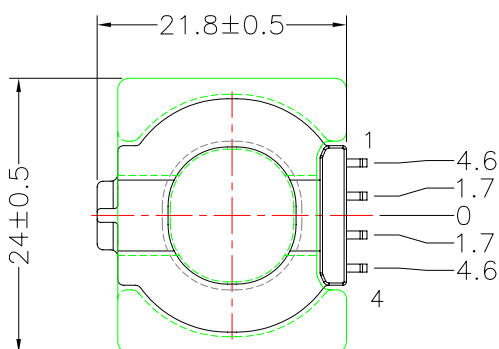

ITEM	PART NO.	MATERIAL	DWG NO.	Core Set Parameters
CORE	ATQ24/11.2A	JPP-44A		$C1=0.319\text{mm}^{-1}$ $Le=33.4\text{mm}$ $Ae=104.5\text{mm}^2$ $Ve=3490.3$
CORE	ATQ24/11.2A	JPP-95		
BOBBIN	TBI-238-01191.11XX		ATQ24-11.2A-4P-THT-1J-11	

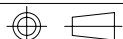

UNIT : m / m

SCALE 1 : 1

REV 1