



TRANSFORMER BOBBIN
INDUSTRIAL CO.,LTD.

Tel : 86-769-88789999 Fax : 86-769-88789989
http:// tbi-tw.com e-mail : tb6688@ms46.hinet.net

REVISIONS

REV	SYM	DRAFTER	CHECKER	DATE
1		X.H.GU	G.F.YANG	01/12/22
2				
3				

除特別指出的A.B兩點強度1.0Kg Min

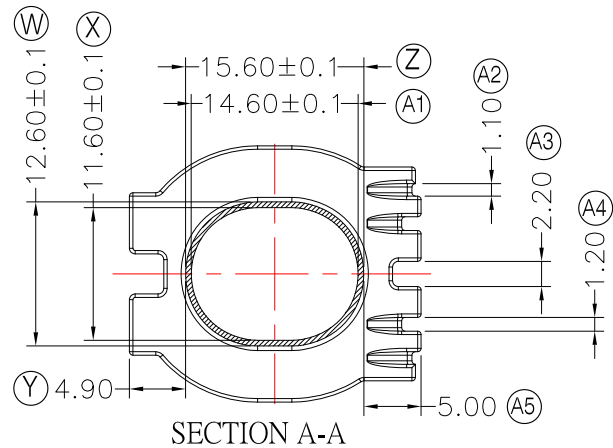
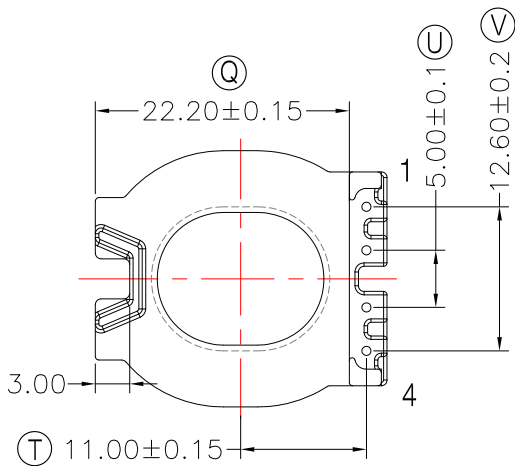
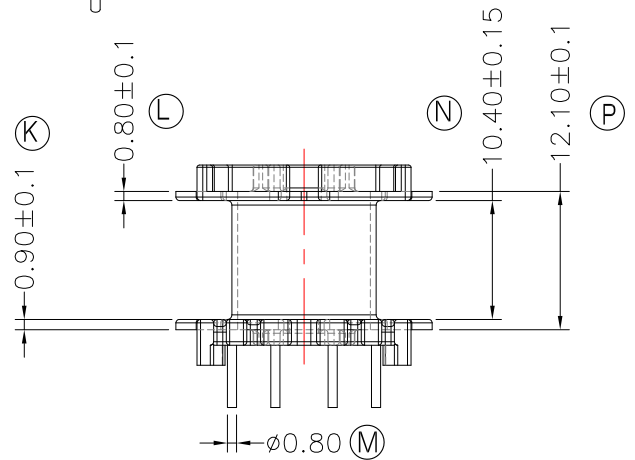
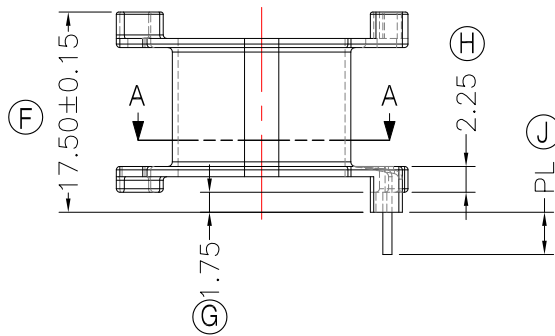
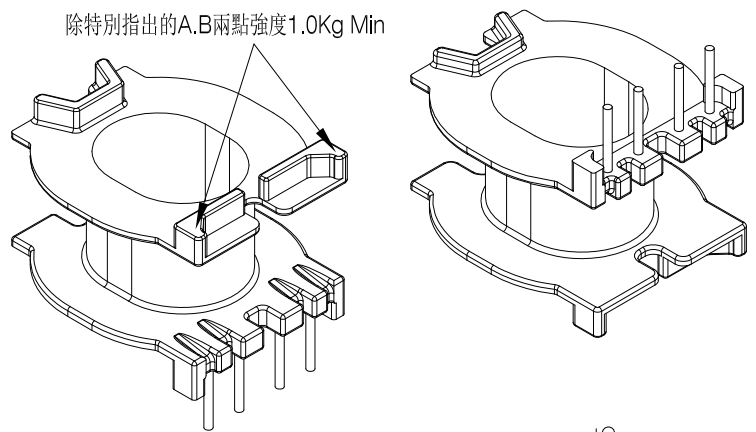
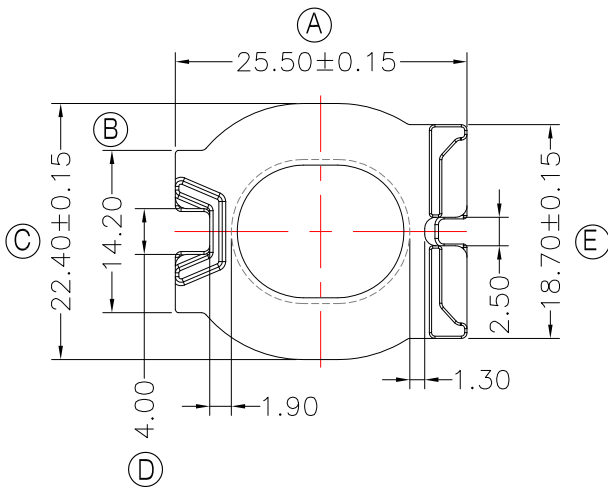

NOTE:

1. 焊錫前拉力: 1.0Kg Min, 焊錫後拉力: 1.5Kg Min.
2. 強度任意一點1.8Kg Min. (除特別指出的A.B兩點強度1.0Kg Min外)

DWG NO. ATQ27-18.4-1-4P-TH-C8-17

PART NO.	MATERIAL (BOBBIN)	MATERIAL (TERMINAL)	TERMINAL (PLATING)	PIN ALLOCATION	NOTE
TBI-238-03381.1706	PM-9823	CP WIRE	Sn	ALL PIN PL=3.7±0.2	S
TBI-238-03381.1716	PM-9823	CP WIRE	Sn	ALL PIN PL=3.2±0.2	H

TOLERANCE: 0<L<=4:±0.1 4<L<=16:±0.2 16<L<=63:±0.3

UNIT : m / m

SCALE 1 : 1

Finish: 1. PB wire Immersion Sn on terminal : Thickness:Sn plating,100%,5 μm (200 μ inches) min,Base nickel 0.625 μm (25 μ inches) min.
2. CP wire Immersion Sn on terminal : Thickness:Sn plating,100%,5 μm (200 μ inches) min.
3. Coplanarity deviation: 0.10 mm (0.004 inches) max.

REV 1