



TRANSFORMER BOBBIN INDUSTRIAL CO.,LTD.

Tel : 86-769-88789999 Fax : 86-769-88789989
http:// tbi-tw.com e-mail : tb6688@ms46.hinet.net

REVISIONS

REV	SYM	DRAFTER	CHECKER	DATE
①		X.H.GU	G.F.YANG	04/26/16
②				
③				

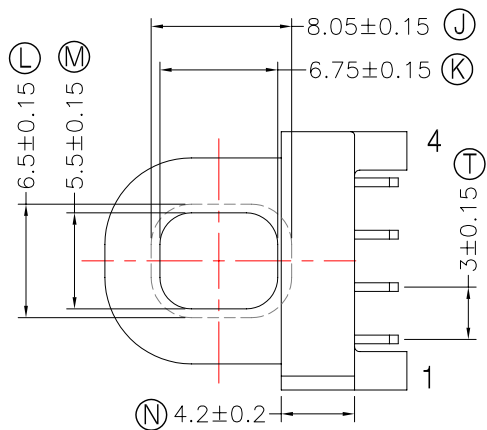
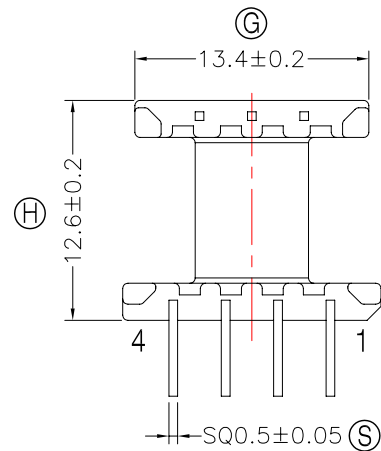
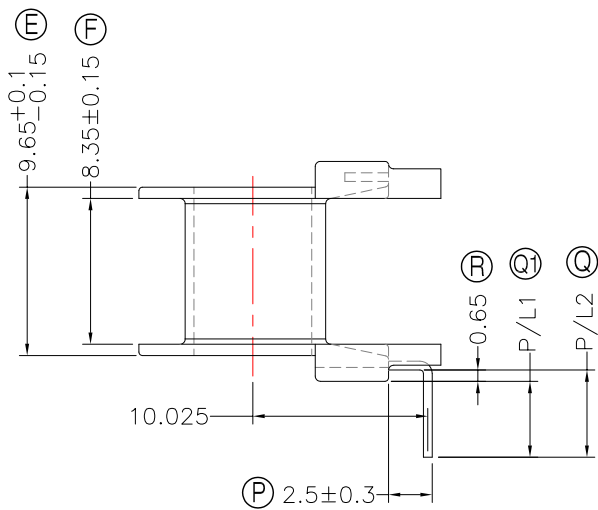
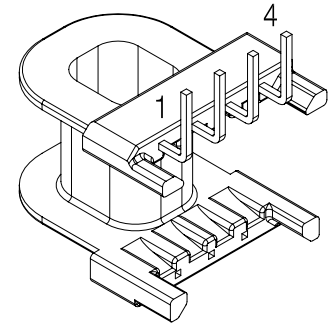
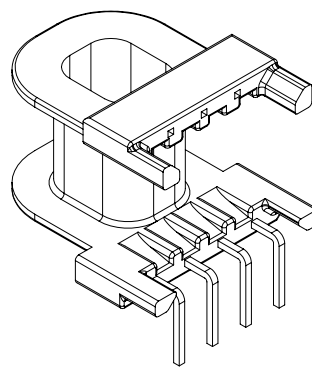
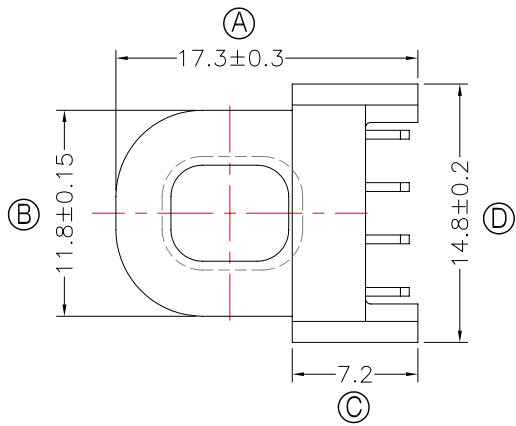

NOTE:

- 1.任意一點強度須1.5kg MIN;
- 2.耐壓4.0Kv /1.5mA 60S;
- 3.焊錫溫度:450°±10° 3SEC
- 4.焊錫前拉力:1.0KG MIN,焊錫後拉力:1.5KG MIN;
- 5.WINDING SPACE:8.35mm*2.65mm=22.13 mm²

DWG NO. ATP15-13-4P-TL-1J-11

PART NO. MATERIAL (BOBBIN) MATERIAL (TERMINAL) TERMINAL (PLATING) PIN ALLOCATION NOTE

TBI-238-27191.1106	PM-9630	CP WIRE	Sn	ALL PIN P/L1=4.35±0.3 P/L2=5.0±0.3	S
TBI-238-27191.1116	PM-9630	CP WIRE	Sn	CUT PIN,2,4 P/L1=4.35±0.3 P/L2=5.0±0.3	H
TBI-238-27191.1126	PM-9630	CP WIRE	Sn	CUT PIN,2,4 P/L1=5.0±0.3 P/L2=5.65±0.3	

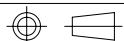

TOLERANCE: 0<L<=4:±0.1 4<L<=16:±0.2 16<L<=63:±0.3

UNIT : m / m

SCALE 1 : 1

Finish: 1. PB wire Immersion Sn on terminal : Thickness:Sn plating,100%,5 μm (200 μ inches) min,Base nickel 0.625 μm (25 μ inches) min.
2. CP wire Immersion Sn on terminal : Thickness:Sn plating,100%,5 μm (200 μ inches) min.
3. Coplanarity deviation: 0.10 mm (0.004 inches) max.

REV 1