



TRANSFORMER BOBBIN
INDUSTRIAL CO.,LTD.

Tel : 86-769-88789999 Fax : 86-769-88789989
http:// tbi-tw.com e-mail : tb6688@ms46.hinet.net

REVISIONS

REV	SYM	DRAFTER	CHECKER	DATE
1		X.H.GU	G.F.YANG	01/19/18
2				
3				

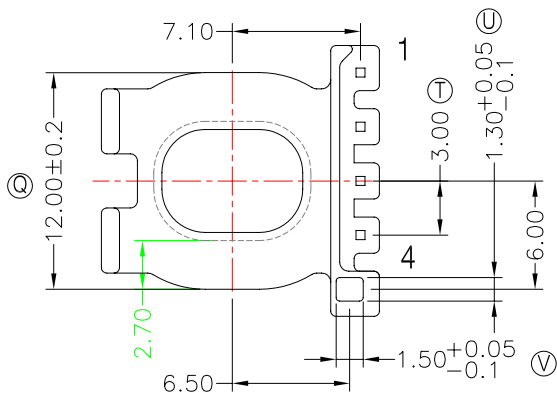
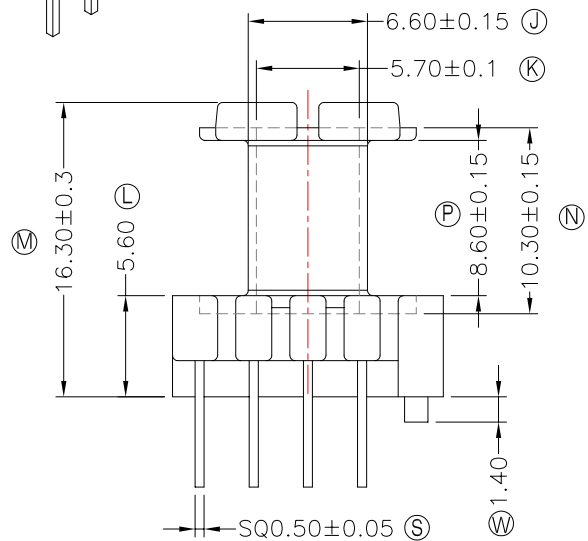
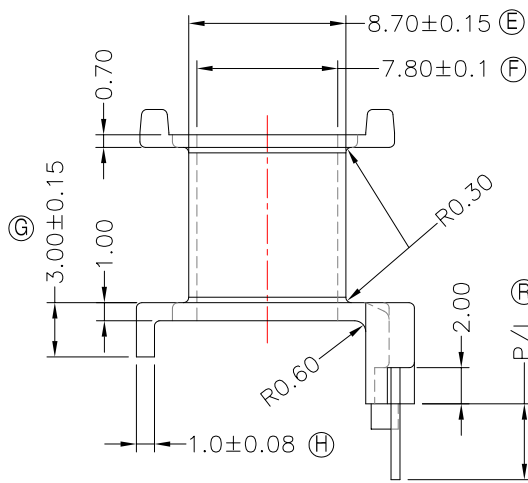
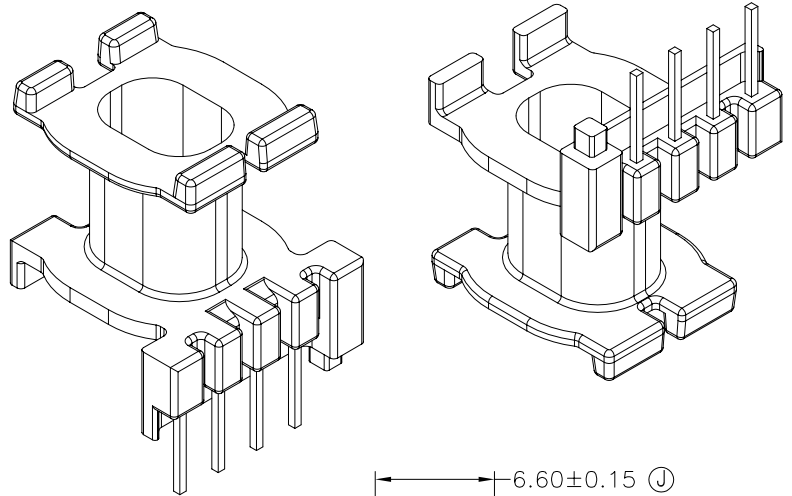
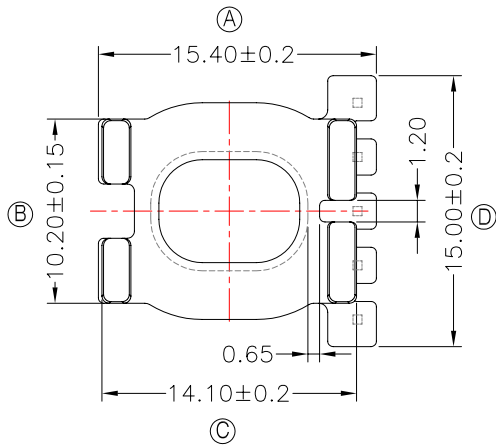

NOTE:

- 耐壓4.0Kv /1.5mA 60S;
- 焊錫溫度:450°±10° 3SEC;
- 任意一點強度須1.8kg MIN;
- 焊錫前拉力:1.0KG MIN,焊錫後拉力:1.5KG MIN;
- WINDING SPACE: 8.6mm*2.7mm=23.22mm²
與TBI-238-46031.11B(ATQ15.5-14.3-BASE-C-11)配套使用;

DWG NO.	ATQ15.5-14.3-4P-TH-C-11				
PART NO.	MATERIAL (BOBBIN)	MATERIAL (TERMINAL)	TERMINAL (PLATING)	PIN ALLOCATION	NOTE
TBI-238-46031.1106	PM-9630	CP WIRE	Sn	ALL PIN P/L=6.0±0.2	S H
TOLERANCE: 0<L<=4:±0.1 4<L<=16:±0.2 16<L<=63:±0.3			UNIT : m / m		SCALE 1 : 1

Finish: 1. PB wire Immersion Sn on terminal : Thickness:Sn plating,100%,5 μm (200 μ inches) min,Base nickel 0.625 μm (25 μ inches) min.
2. CP wire Immersion Sn on terminal : Thickness:Sn plating,100%,5 μm (200 μ inches) min.
3. Coplanarity deviation: 0.10 mm (0.004 inches) max.

REV 1