



TRANSFORMER BOBBIN INDUSTRIAL CO.,LTD.

Tel : 86-769-88789999 Fax : 86-769-88789989
 http:// tbi-tw.com e-mail : tb6688@ms46.hinet.net

REVISIONS

REV	SYM	DRAFTER	CHECKER	DATE
2		T.S.LII	W.H.HSU	04/02/07
3		S.Y.TANG	W.H.HSU	06/06/07
4		S.Y.TANG	W.H.HSU	06/19/07

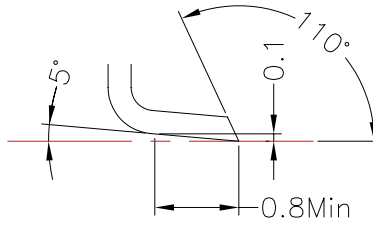
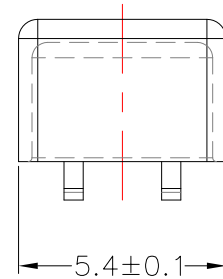
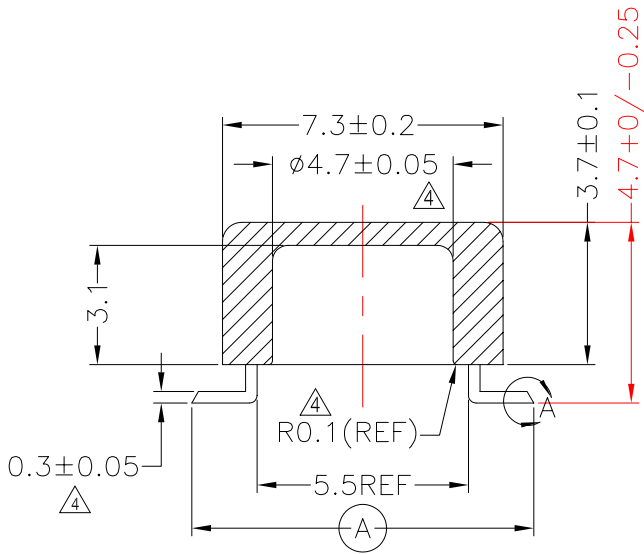
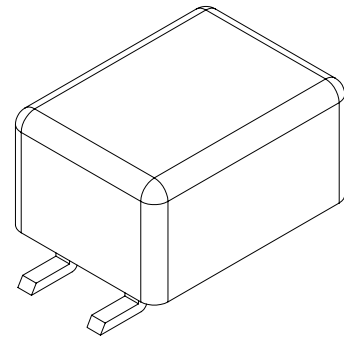
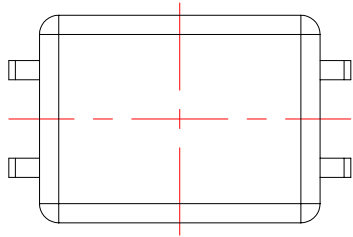

DETAIL:A-10:1
PATENTED

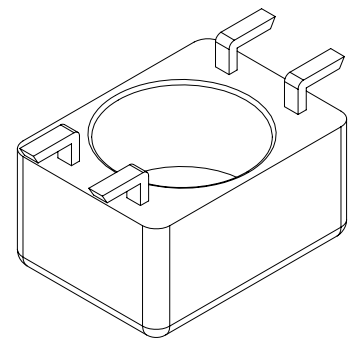
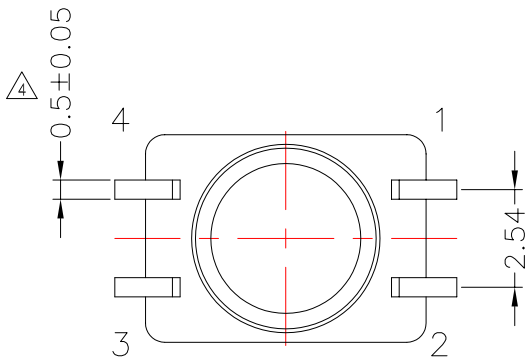

NOTE :1. 焊前拉力&焊後拉力1.0KgMin(焊錫溫度420°C/5S).
 2. CASE 頂部共面度為0.1 MAX.

DWG NO.	K5-4P-L-2.54-A-1				
PART NO.	MATERIAL (BOBBIN)	MATERIAL (TERMINAL)	TERMINAL (PLATING)	PIN ALLOCATION	NOTE
TBI-113-12011.103	PM-9630	PB	Sn	ALL PIN (A)=8.9±0.2	
TBI-113-12011.113	PM-9630	PB	Sn	ALL PIN (A)=7.5±0.2	

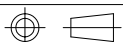

TOLERANCE: .X±0.15 .XX±0.10 .XXX±0.05

UNIT : m/m

SCALE 5 : 1

Finish: 1. PB wire Immersion Sn on terminal : Thickness:Sn plating,100,5 μm (200 μ inches) min,Base nickel 0.625 μm (25 μ inches) min.
 2. CP wire Immersion Sn on terminal : Thickness:Sn plating,100,5 μm (200 μ inches) min.

3. Coplanarity deviation: 0.08 mm (0.003 inches) max.

REV 4