

A-CORE

A-CORE JIANGMEN ELECTRONICS CO.,LTD
 江門安磁電子有限公司

TBI

TRANSFORMER BOBBIN
 INDUSTRIAL CO.,LTD.

ELECTRICAL CO. Tel : 86-750-3867791 Fax : 86-750-3867787

Tel : 86-769-88789999 Fax : 86-769-88789989

e-mail : sales@acore-ferrite.com

http:// tbi-tw.com e-mail : tb6688@ms46.hinet.net

REVISIONS

REV	SYM	DRAFTER	CHECKER	DATE
△1		X.H.GU	G.F.YANG	07/06/10
△2				
△3				

TOP

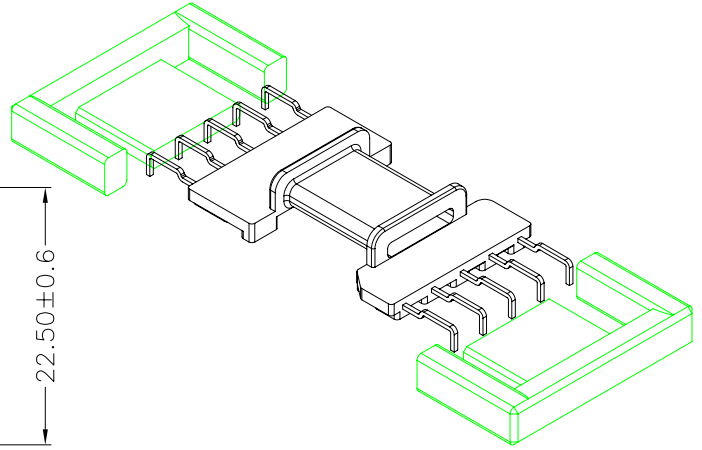
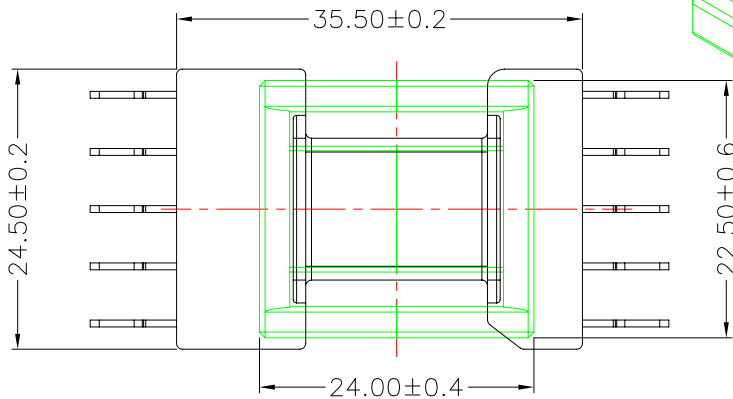

TOP

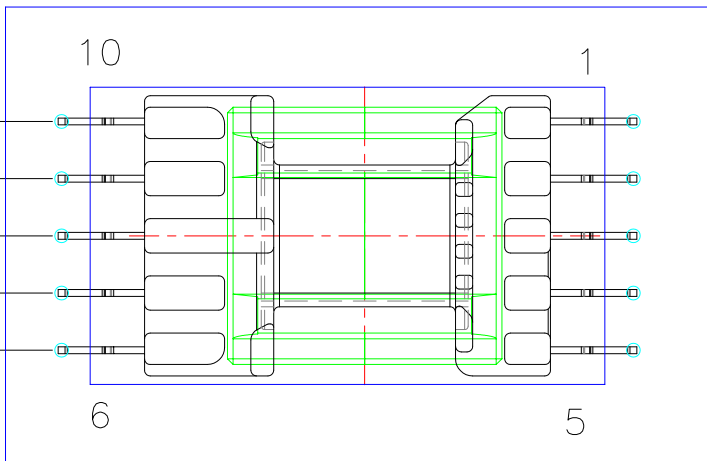
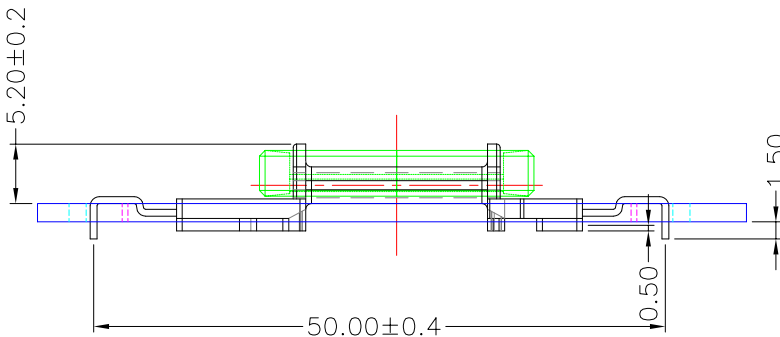
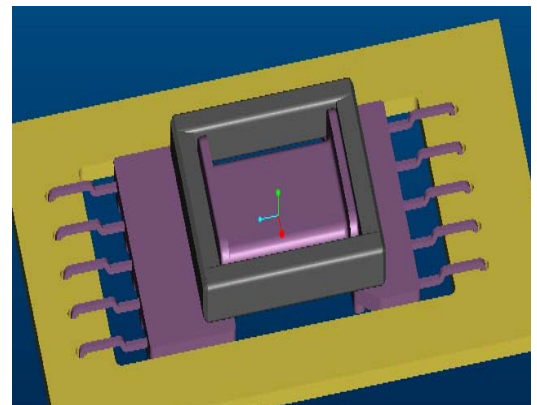

BOTTOM

BOTTOM

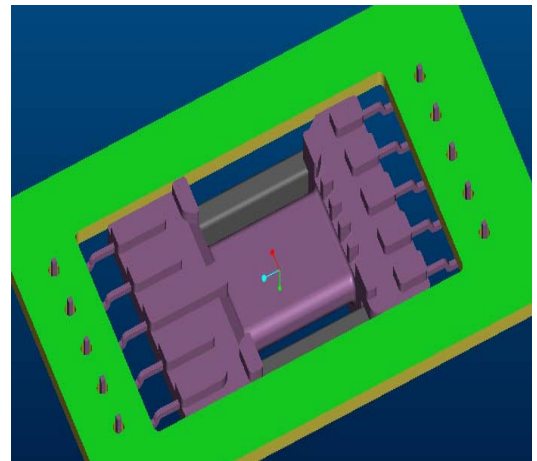

ITEM	PART NO.	MATERIAL	DWG NO.	Core Set Parameters
CORE	EFD22.5-24	JPP-44A		C1=2.54mm ⁻¹ Le=54mm Ae=21.3mm ² Ve=1150.2mm ³
CORE	EFD22.5-24	JPP-95		
BOBBIN	TBI-207-07091.11XX		EFD22.5-24-10P-THT-0J-11	

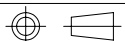

UNIT : m / m

SCALE 1 : 1

REV 1