



TRANSFORMER BOBBIN
INDUSTRIAL CO.,LTD.

Tel : 86-769-88789999 Fax : 86-769-88789989
http:// tbi-tw.com e-mail : tb6688@ms46.hinet.net

REVISIONS

REV	SYM	DRAFTER	CHECKER	DATE
1		X.H.GU	G.F.YANG	09/18/15
2		X.H.GU	G.F.YANG	11/27/15
3				

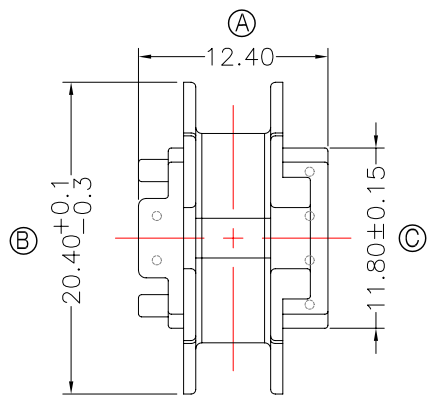

A 強度1.3Kg MIN

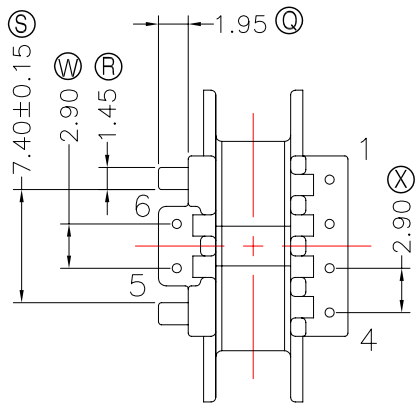
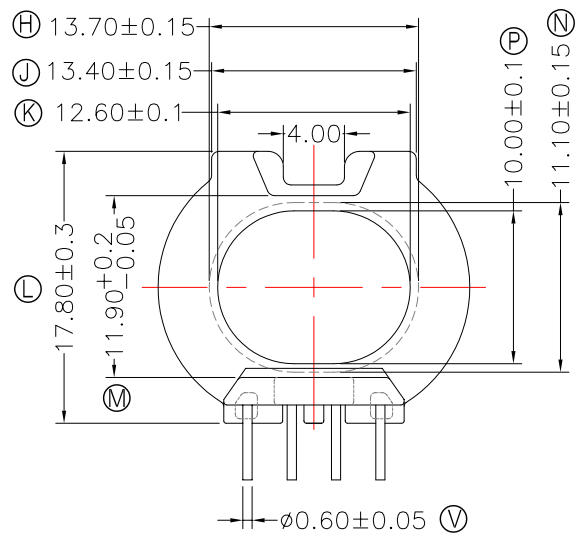
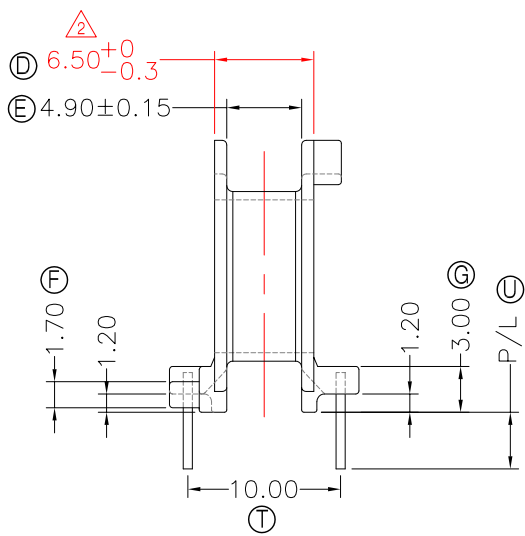
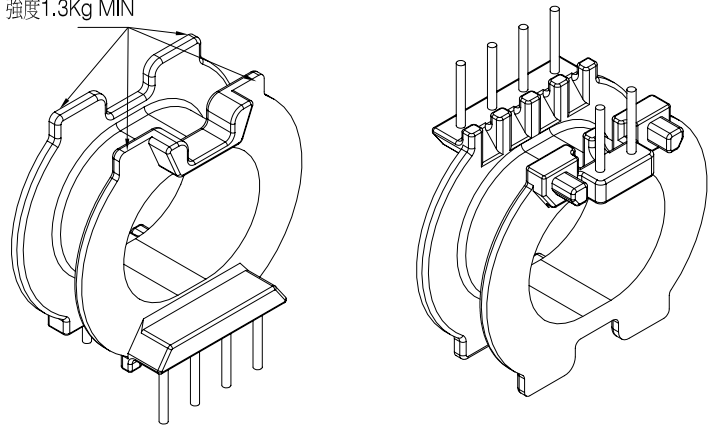

NOTE:

- 耐壓4.0Kv /1.5mA 60S;
- 焊錫溫度:450°±10° 3SEC
- 任一點的強度為1.5kg MIN, 其中.A.處為1.3kg MIN
- 焊錫前拉力:1.0KG MIN, 焊錫後拉力:1.5KG MIN;
- Winding Space=4.9*3.35=16.41mm²

與TBI-238-10441.11XX(ATQ23.7-12.9A-3P-CASE-D4-11)配套使用;

DWG NO. ATQ23.7-12.9A-6P-TH-D3-11

PART NO.	MATERIAL (BOBBIN)	MATERIAL (TERMINAL)	TERMINAL (PLATING)	PIN ALLOCATION	NOTE
TBI-238-10431.1106	PM-9630	CP WIRE	Sn	ALL PIN P/L=3.7±0.2	S
TBI-238-10431.1116	PM-9630	CP WIRE	Sn	ALL PIN P/L=5.0±0.2	H
TBI-238-10431.1126	PM-9630	CP WIRE	Sn	NO PIN#5 P/L=5.0±0.2	
TBI-238-10431.1136	PM-9630	CP WIRE	Sn	NO PIN#4 P/L=5.0±0.2	

TOLERANCE: 0<L<=4: ±0.1 4<L<=16: ±0.2 16<L<=63: ±0.3 UNIT : m / m SCALE 1 : 1

Finish: 1. PB wire Immersion Sn on terminal : Thickness:Sn plating,100%,5 μm (200 μ inches) min,Base nickel 0.625 μm (25 μ inches) min.

2. CP wire Immersion Sn on terminal : Thickness:Sn plating,100%,5 μm (200 μ inches) min.

3. Coplanarity deviation: 0.10 mm (0.004 inches) max.

REV 2

A-CORE
ELECTRICAL CO.

A-CORE JIANGMEN ELECTRONICS CO.,LTD
江門安磁電子有限公司
Tel : 86-750-3867791 Fax : 86-750-3867787

REVISIONS				
REV	SYM	DRAFTER	CHECKER	DATE
①		X.H.GU	G.F.YANG	08/31/15
②				
③				

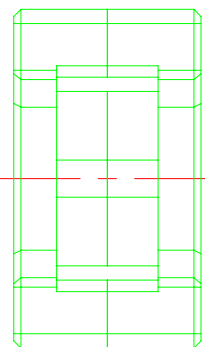
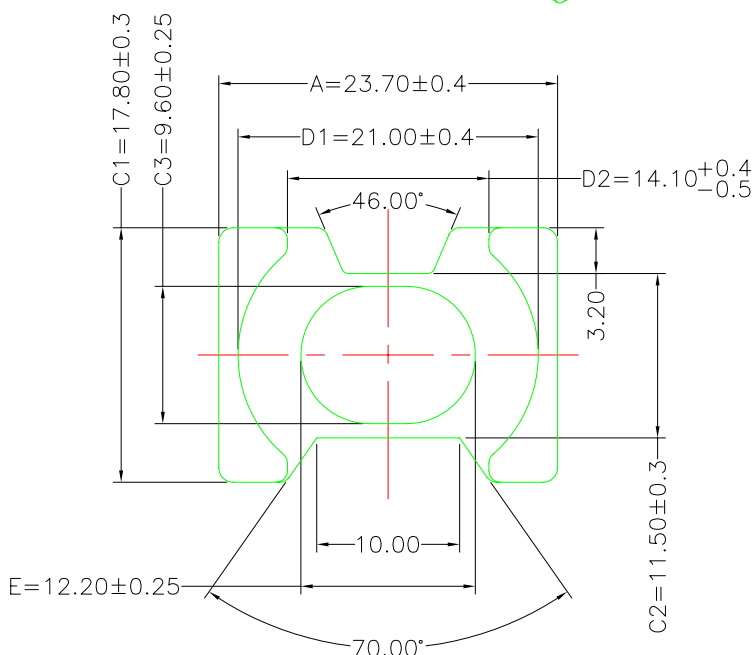
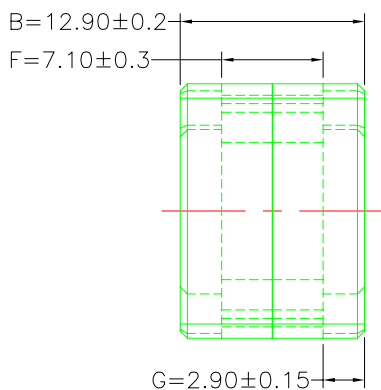
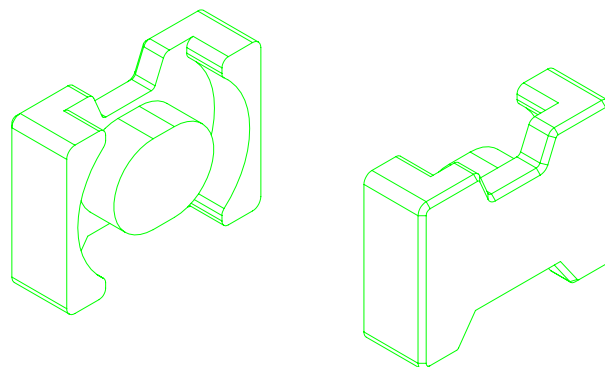
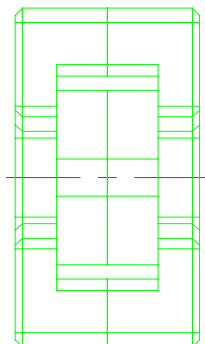

Core Set Parameters

$A_e = 100 \text{mm}^2$
 $L_e = 35.2 \text{mm}$
 $C1 = 0.352 \text{mm}^{-1}$
 $V_e = 3520 \text{mm}^3$

DWG NO.	ATQ23.7/12.9A CORE				
PART NO.	MATERIAL (BOBBIN)	MATERIAL (TERMINAL)	TERMINAL (PLATING)	PIN ALLOCATION	NOTE
ATQ23.7/12.9A	JPP-44A				
ATQ23.7/12.9A	JPP-95				

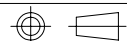

TOLERANCE: $0 < L \leq 4: \pm 0.1$ $4 < L \leq 16: \pm 0.2$ $16 < L \leq 63: \pm 0.3$

UNIT : m / m

SCALE 1 : 1

REV 1

A-CORE

A-CORE JIANGMEN ELECTRONICS CO.,LTD
 江門安磁電子有限公司

TBI

TRANSFORMER BOBBIN
 INDUSTRIAL CO.,LTD.

ELECTRICAL CO. Tel : 86-750-3867791 Fax : 86-750-3867787

Tel : 86-769-88789999 Fax : 86-769-88789989

e-mail : sales@acore-ferrite.com

http:// tbi-tw.com e-mail : tb6688@ms46.hinet.net

REVISIONS

REV	SYM	DRAFTER	CHECKER	DATE
△1		X.H.GU	G.F.YANG	09/18/15
△2		X.H.GU	G.F.YANG	03/16/16
△3				

TOP

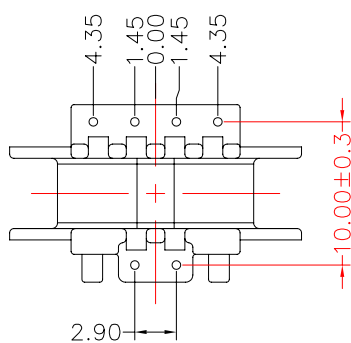
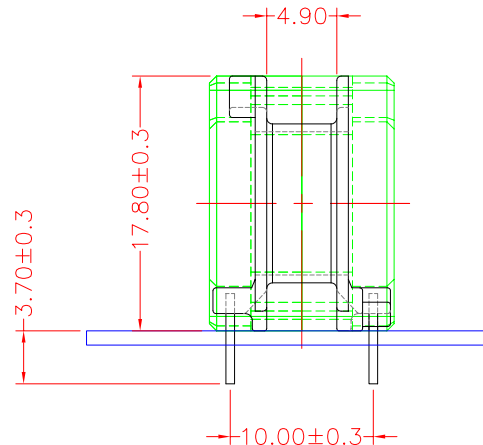
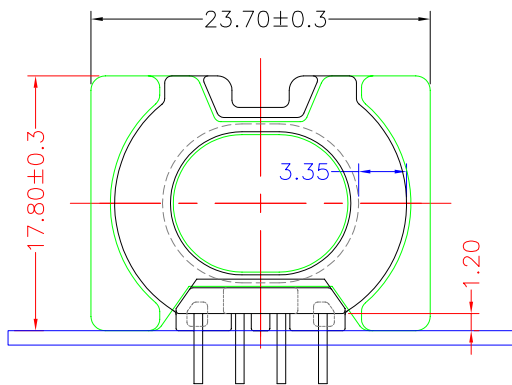
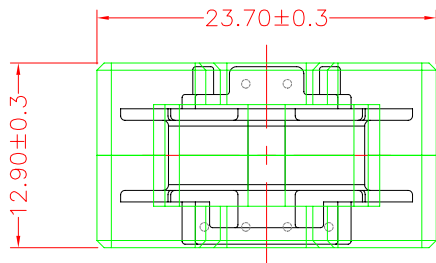

ITEM	PART NO.	MATERIAL	DWG NO.	Core Set Parameters
CORE	ATQ23.7/12.9A	JPP-44A		$A_e=100\text{mm}^2$ $L_e=35.2\text{mm}$ $C_1=0.352\text{mm}^{-1}$ $V_e=3520\text{mm}^3$
CORE	ATQ23.7/12.9A	JPP-95		
BOBBIN	TBI-238-10431.11XX		ATQ23.7-12.9A-6P-TH-D3-11	

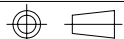

UNIT : m / m

SCALE 1 : 1

REV 2