





**A-CORE**

A-CORE JIANGMEN ELECTRONICS CO.,LTD  
 江門安磁電子有限公司

**TBI**

TRANSFORMER BOBBIN  
 INDUSTRIAL CO.,LTD.

ELECTRICAL CO. Tel : 86-750-3867791 Fax : 86-750-3867787

Tel : 86-769-88789999 Fax : 86-769-88789989

e-mail : sales@acore-ferrite.com

http:// tbi-tw.com e-mail : tb6688@ms46.hinet.net

REVISIONS

REV	SYM	DRAFTER	CHECKER	DATE
△4		X.H.GU	G.F.YANG	03/09/11
△5		X.H.GU	G.F.YANG	03/25/11
△6		X.H.GU	G.F.YANG	05/05/11

TOP

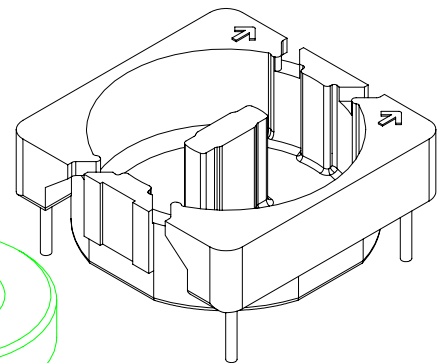
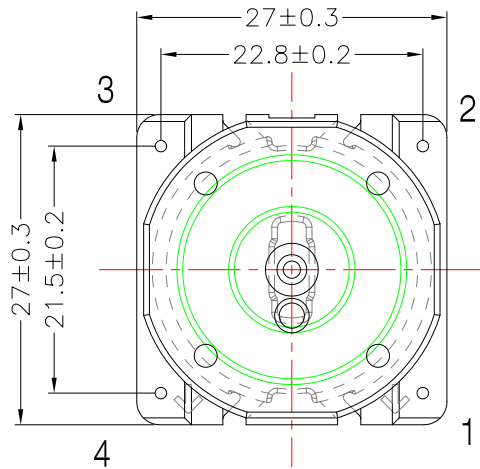

TOP

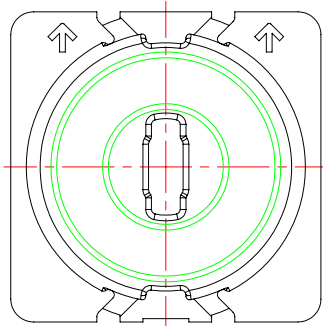
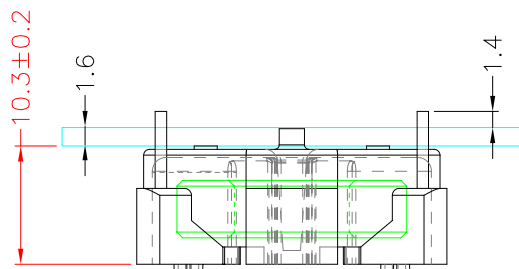
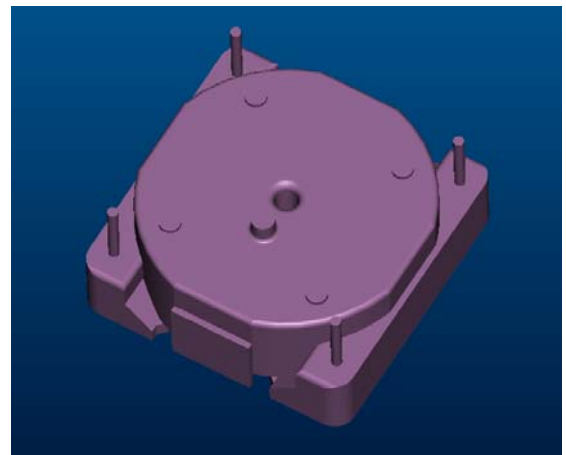

BOTTOM

BOTTOM

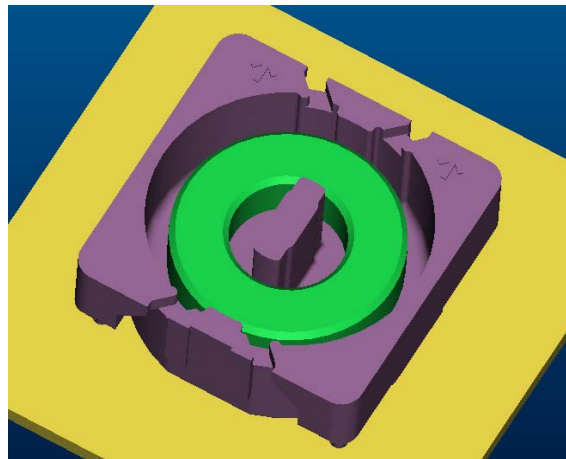

ITEM	PART NO.	MATERIAL	DWG NO.	Core Set Parameters
CORE	OR20X5-10C	JPH-10F		$A_e=24\text{mm}^2$ $L_e=43.6\text{mm}$ $C_1=1.82\text{mm}^{-1}$ $V_e=1046.4\text{mm}^3$
BASE	TBI-220-16141.12XX		OR20X5-10C-BASE-A4-12	
				UNIT : m/m
				SCALE 1:1

REV 6