

A-CORE

A-CORE JIANGMEN ELECTRONICS CO.,LTD
 江門安磁電子有限公司

TBI

TRANSFORMER BOBBIN
 INDUSTRIAL CO.,LTD.

ELECTRICAL CO. Tel : 86-750-3867791 Fax : 86-750-3867787

Tel : 86-769-88789999 Fax : 86-769-88789989

e-mail : sales@acore-ferrite.com

http:// tbi-tw.com e-mail : tb6688@ms46.hinet.net

REVISIONS

REV	SYM	DRAFTER	CHECKER	DATE
△1		X.H.GU	G.F.YANG	06/09/15
△2		F.LU	G.F.YANG	01/21/16
△3				

TOP

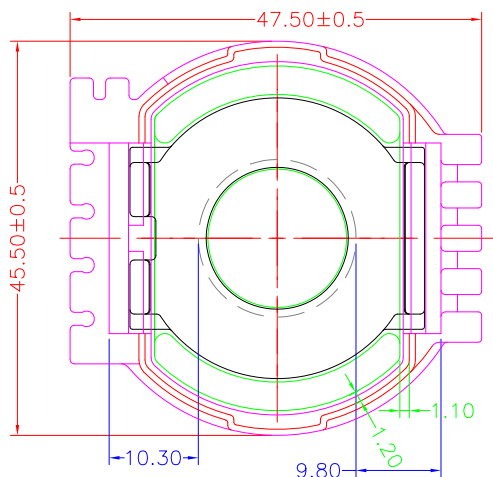

TOP

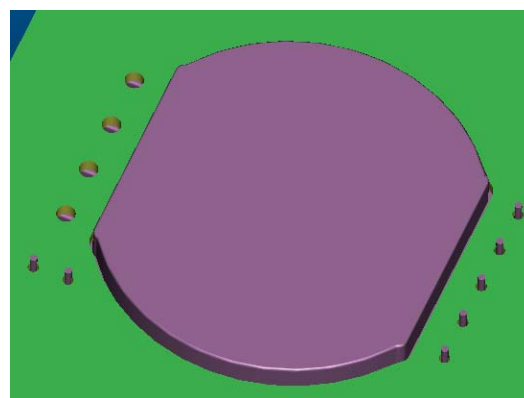
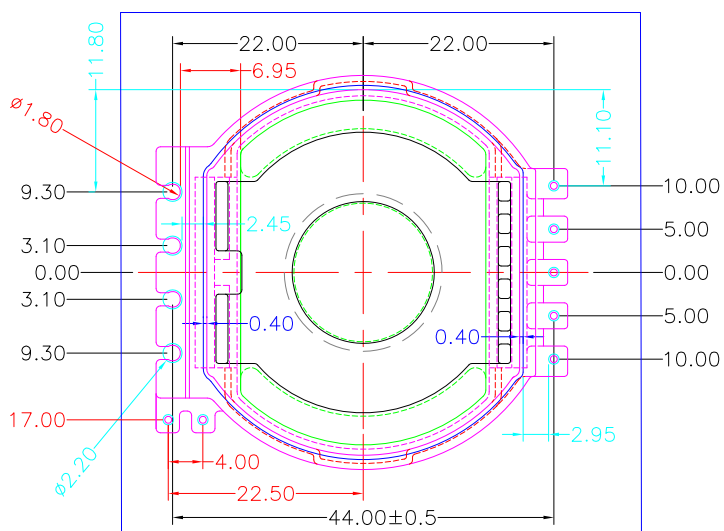
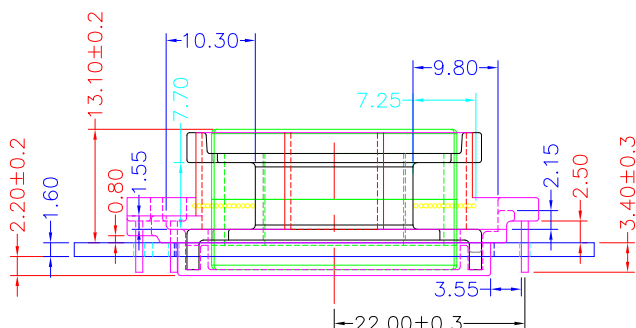
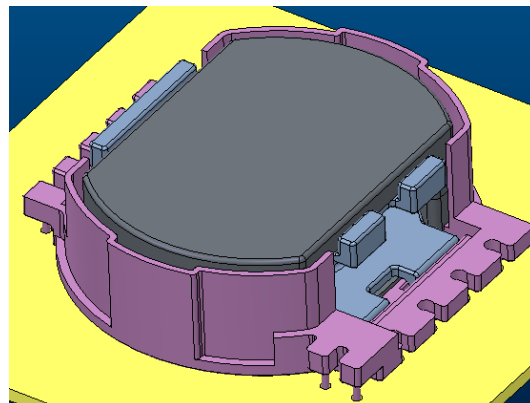

BOTTOM

BOTTOM

ITEM	PART NO.	MATERIAL	DWG NO.
CORE	CC40/16.2D	JPP-44A	
CORE	CC40/16.2D	JPP-95	
BOBBIN	TBI-239-01491.11		CC40-16.2D-NA-D9-11
CASE	TBI-239-01521.11XX		CC40-16.2D-7P-CASE-E2-11

Core Set Parameters

$A_e=183.0\text{mm}^2$
 $L_e=48.7\text{mm}$
 $C_1=0.266\text{mm}^{-1}$
 $V_e=8912.1\text{mm}^3$

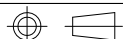

UNIT : m/m

SCALE 1 : 1

REV 2