



**TRANSFORMER BOBBIN
INDUSTRIAL CO.,LTD.**

Tel : 86-769-88789999 Fax : 86-769-88789989
 http:// tbi-tw.com e-mail : tb6688@ms46.hinet.net

REVISIONS

REV	SYM	DRAFTER	CHECKER	DATE
①		X.H.GU	G.F.YANG	07/31/14
②				
③				

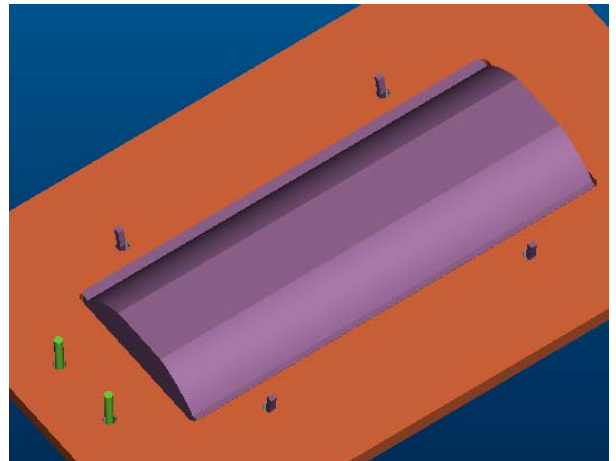
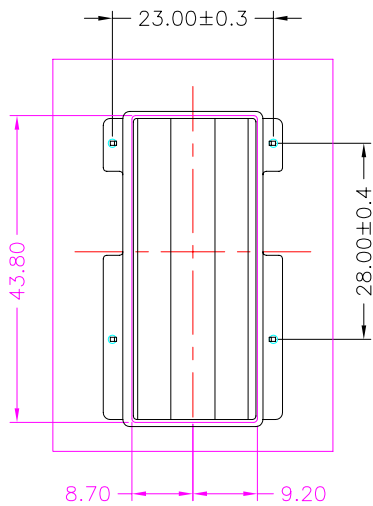
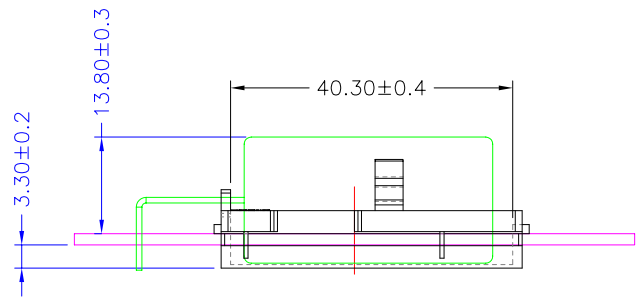
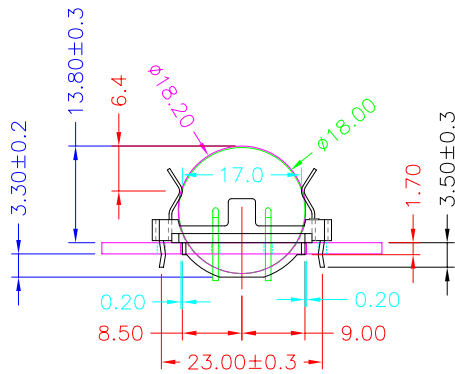
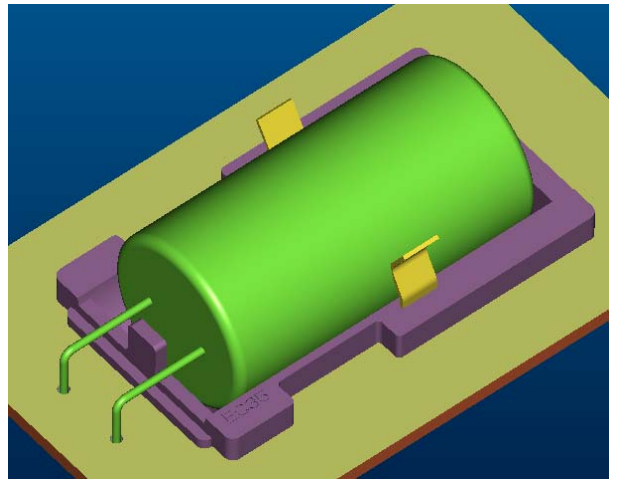
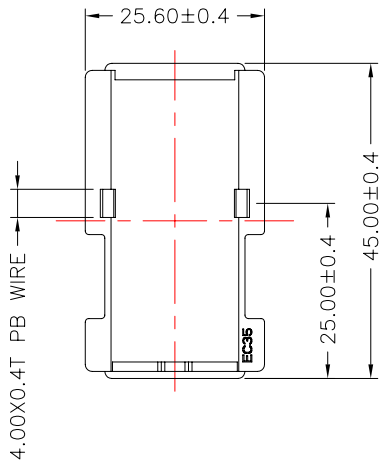

DWG NO. assembly diagram

PART NO. MATERIAL (BOBBIN) MATERIAL (TERMINAL) TERMINAL (PLATING) PIN ALLOCATION NOTE

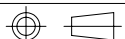

TOLERANCE:0<L<=4:±0.1 4<L<=16:±0.2 16<L<=63:±0.3

UNIT : m/m

SCALE 1 : 1

Finish:

REV 1