

A-CORE

A-CORE JIANGMEN ELECTRONICS CO.,LTD
江門安磁電子有限公司

TBI

TRANSFORMER BOBBIN
INDUSTRIAL CO.,LTD.

ELECTRICAL CO. Tel : 86-750-3867791 Fax : 86-750-3867787

Tel : 86-769-88789999 Fax : 86-769-88789989

e-mail : sales@acore-ferrite.com

http:// tbi-tw.com e-mail : tb6688@ms46.hinet.net

REVISIONS

REV	SYM	DRAFTER	CHECKER	DATE
△1		X.H.GU	G.F.YANG	01/29/10
△2		G.F.YANG	W.H.HSU	03/12/10
△3		YAN.TANG	G.F.YANG	11/17/10

TOP

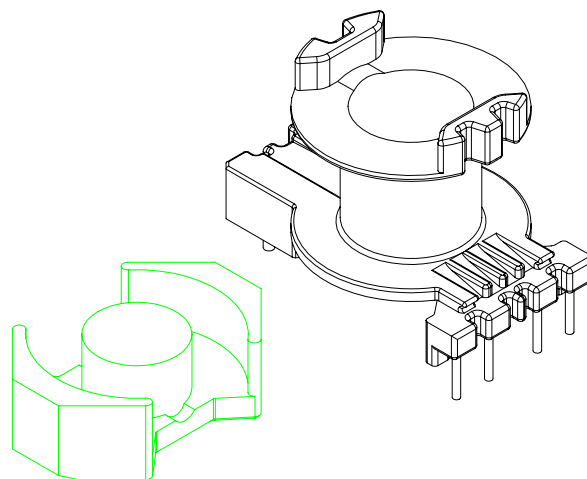
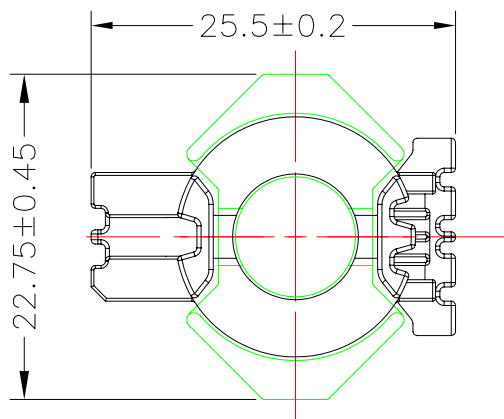

TOP

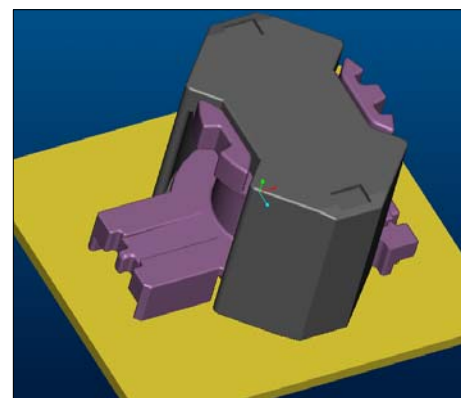
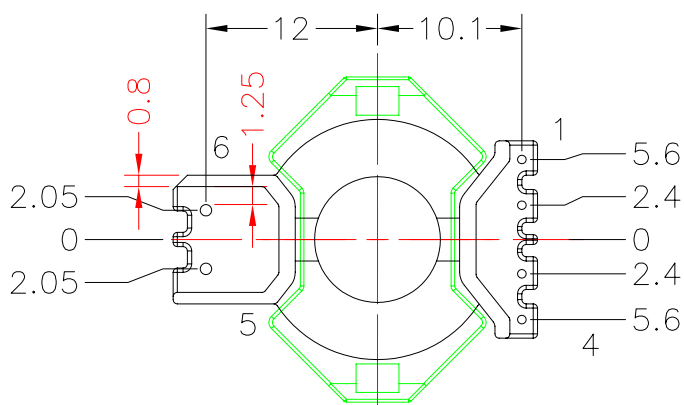
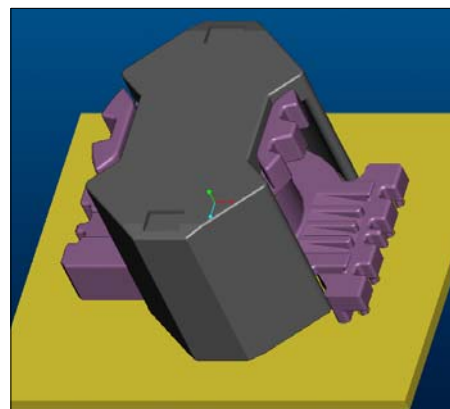
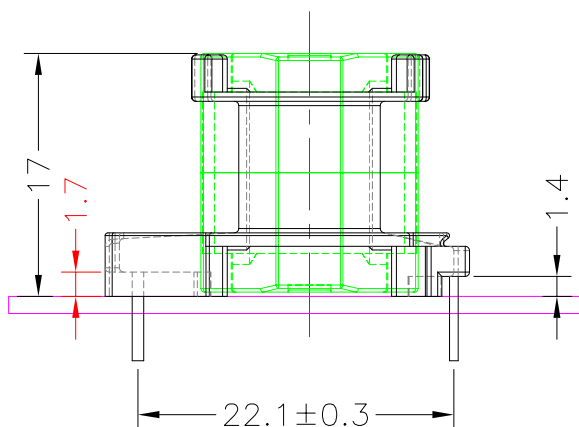

BOTTOM

ITEM	PART NO.	MATERIAL	DWG NO.	Core Set Parameters
CORE	RM8-16.7	JPP-44A		$A_e=64.0\text{mm}^2$ $L_e=38.0\text{mm}$ $C_1=0.594\text{mm}^{-1}$ $V_e=2432\text{mm}^3$
CORE	RM8-16.7	JPP-95		
BOBBIN	TBI-208-05121.11XX		RM8-6P-TH-A2-11	

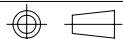

UNIT : m/m

SCALE 1 : 1

REV 3