



TRANSFORMER BOBBIN
INDUSTRIAL CO.,LTD.

Tel : 86-769-88789999 Fax : 86-769-88789989
http:// tbi-tw.com e-mail : tb6688@ms46.hinet.net

REVISIONS

REV	SYM	DRAFTER	CHECKER	DATE
2		X.H.GU	G.F.YANG	04/07/15
3		X.H.GU	G.F.YANG	04/14/15
4		X.H.GU	G.F.YANG	04/22/15

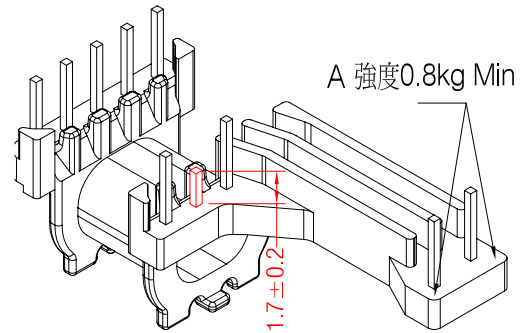
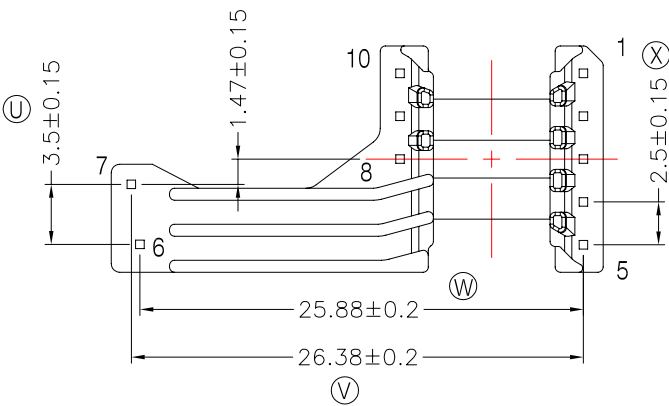
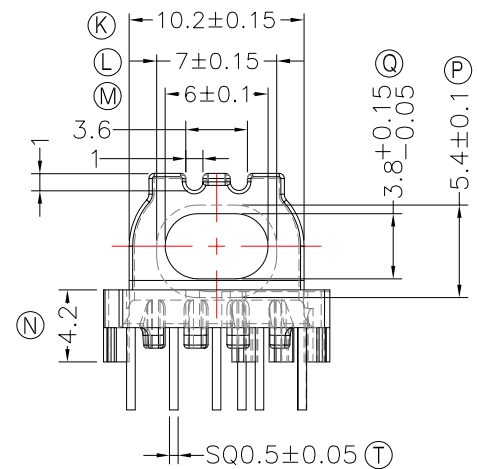
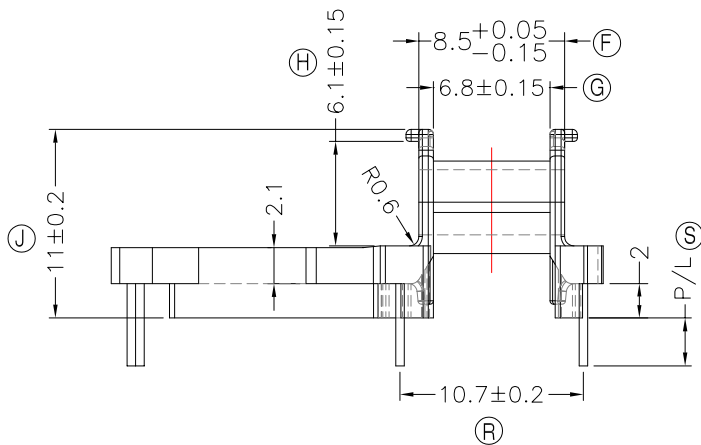
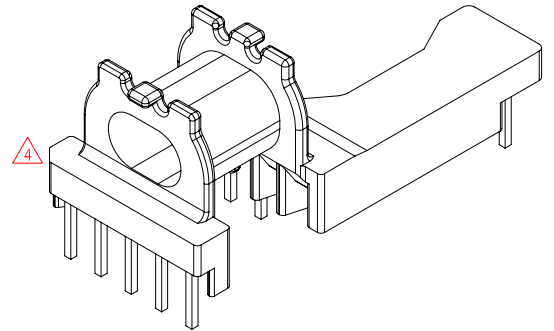
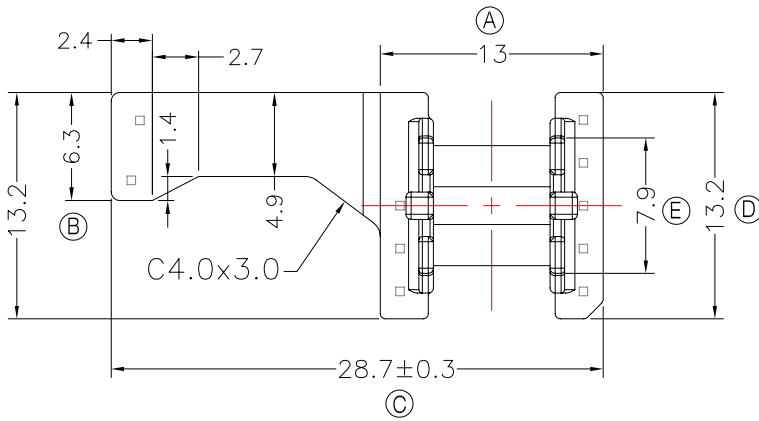

NOTE:

- 耐壓4.0Kv /1.5mA 60S;
- 焊錫溫度:450°±10° 3SEC
- 焊錫前拉力:1.0kg Min,焊錫後拉力:1.5kg Min;
- 任意一點強度須1.5kg Min;(除以下測試點,A.處為0.8kg Min).

只針對1126料號

DWG NO. EPC13-13C-10P-TH-A5-11

PART NO.	MATERIAL (BOBBIN)	MATERIAL (TERMINAL)	TERMINAL (PLATING)	PIN ALLOCATION	NOTE
TBI-206-04151.1106	PM-9630	CP WIRE	Sn	ALL PIN P/L=2.8±0.2	S
TBI-206-04151.1116	PM-9630	CP WIRE	Sn	NO PIN#3,8,10 P/L=2.8±0.2	H
TBI-206-04151.1126	PM-9630	CP WIRE	Sn	NO PIN#3,8,10, P/L=2.8±0.2 (PIN#9長度1.7±0.2,從插PIN底面量起.)	
TBI-206-04151.1136	PM-9630	CP WIRE	Sn	ALL PIN P/L=3.5±0.2	
TBI-206-04151.1146	PM-9630	CP WIRE	Sn	NO PIN#3,8,9,10 P/L=3.5±0.2	
TBI-206-04151.1156	PM-9630	CP WIRE	Sn	NO PIN#3,8,9,10 P/L=3.2±0.2	

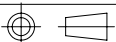

TOLERANCE: 0<L<=4:±0.1 4<L<=16:±0.2 16<L<=63:±0.3

UNIT : m / m

SCALE 1 : 1

Finish: 1. PB wire Immersion Sn on terminal : Thickness:Sn plating,100%,5 μm (200 μinches) min,Base nickel 0.625 μm (25 μ inches) min.
2. CP wire Immersion Sn on terminal : Thickness:Sn plating,100%,5 μm (200 μinches) min.
3. Coplanarity deviation: 0.10 mm (0.004 inches)max.

REV 4

A-CORE
ELECTRICAL CO.

A-CORE JIANGMEN ELECTRONICS CO.,LTD
江門安磁電子有限公司
Tel : 86-750-3867791 Fax : 86-750-3867787

REVISIONS				
REV	SYM	DRAFTER	CHECKER	DATE
①		X.H.GU	G.F.YANG	12/04/12
②				
③				

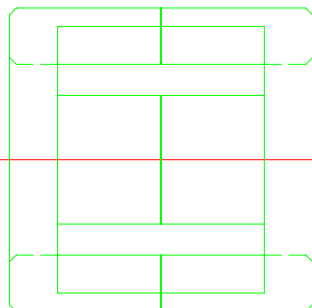
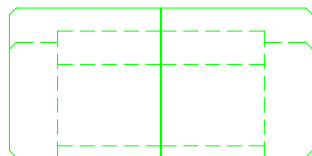
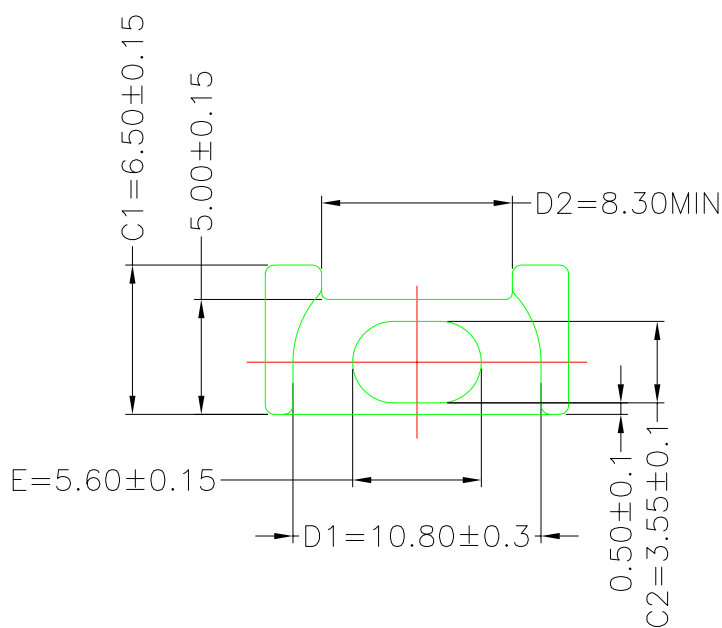
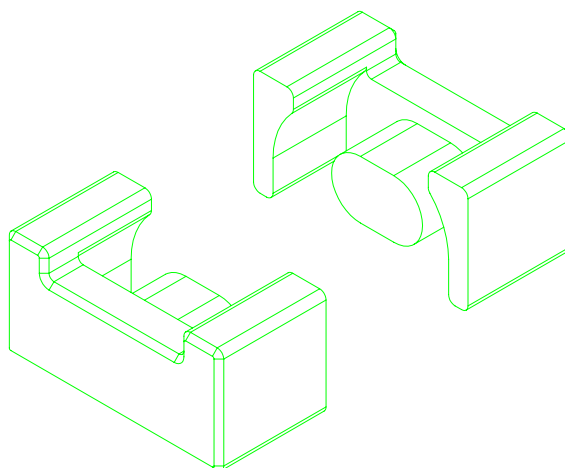
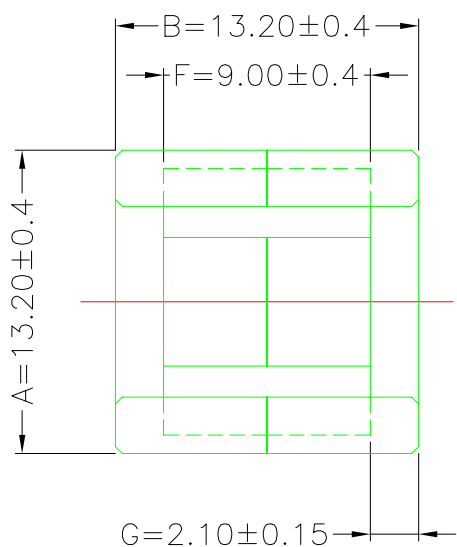

Core Set Parameters

$A_e = 19.2 \text{ mm}^2$

$L_e = 33.0 \text{ mm}$

$C1 = 1.72 \text{ mm}^{-1}$

$V_e = 633.6 \text{ mm}^3$

DWG NO.	EPC13/13C- CORE				
PART NO.	MATERIAL (CORE)	MATERIAL (TERMINAL)	TERMINAL (PLATING)	PIN ALLOCATION	NOTE
EPC13/13C	JPP-44A				
EPC13/13C	JPP-95				

Finish:	TOLERANCE: $0 < L \leq 4: \pm 0.1$ $4 < L \leq 16: \pm 0.2$ $16 < L \leq 63: \pm 0.3$	UNIT : m / m	SCALE 1 : 1
			REV 1

A-CORE

A-CORE JIANGMEN ELECTRONICS CO.,LTD
 江門安磁電子有限公司

TBI

TRANSFORMER BOBBIN
 INDUSTRIAL CO.,LTD.

ELECTRICAL CO. Tel : 86-750-3867791 Fax : 86-750-3867787

Tel : 86-769-88789999 Fax : 86-769-88789989

e-mail : sales@acore-ferrite.com

http:// tbi-tw.com e-mail : tb6688@ms46.hinet.net

REVISIONS

REV	SYM	DRAFTER	CHECKER	DATE
△2		X.H.GU	G.F.YANG	04/07/15
△3		X.H.GU	G.F.YANG	04/14/15
△4		X.H.GU	G.F.YANG	04/22/15

TOP

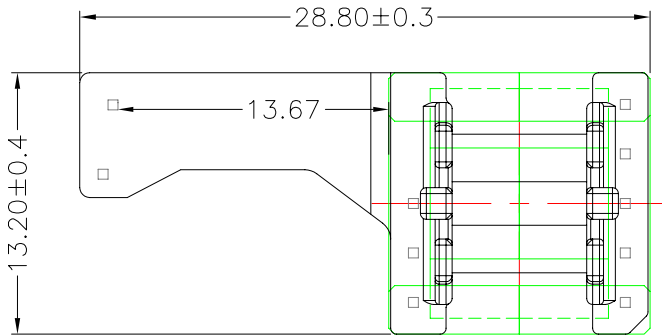

TOP

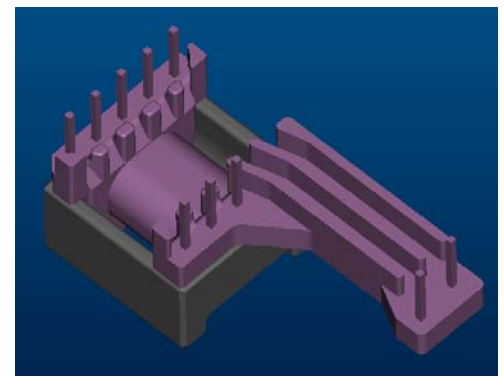
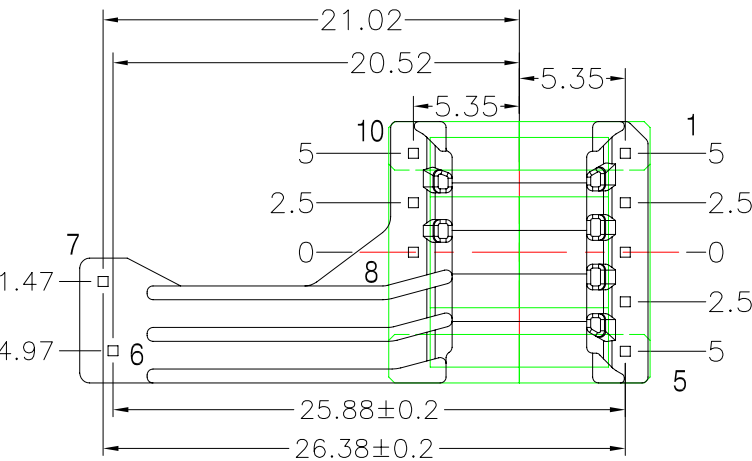
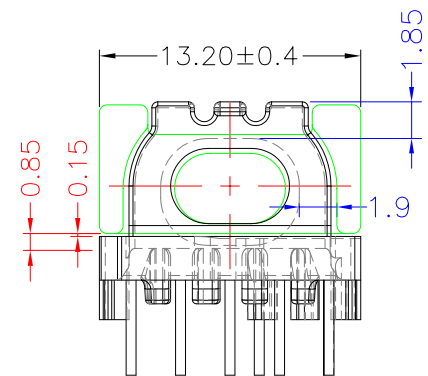
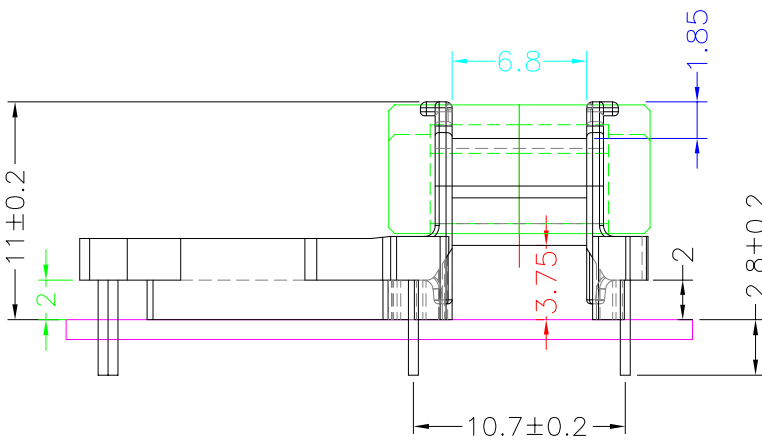
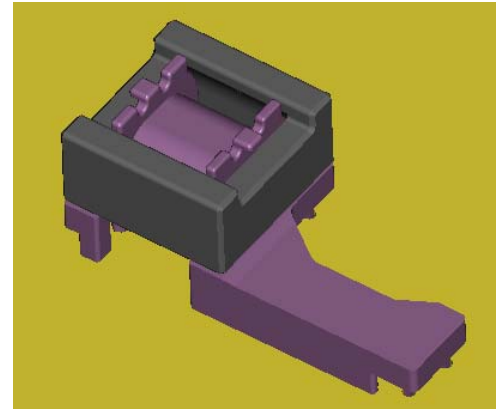

BOTTOM

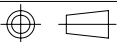
ITEM	PART NO.	MATERIAL	DWG NO.	Core Set Parameters
CORE	EPC13/13C	JPP-44A		Ae=19.2mm ² Le=33.0mm C1=1.72mm ⁻¹ Ve=633.6mm ³
CORE	EPC13/13C	JPP-95		
BOBBIN	TBI-206-04151.11XX		EPC13-13C-10P-TH-A5-11	
 UNIT : m/m				SCALE 1 : 1

REV 4