

TBI TRANSFORMER BOBBIN INDUSTRIAL CO.,LTD.

Tel : 86-769-88789999 Fax : 86-769-88789989
 http:// tbi-tw.com e-mail : tb6688@ms46.hinet.net

REVISIONS				
REV	SYM	DRAFTER	CHECKER	DATE
△2		X.H.GU	G.F.YANG	03/13/18
△3				
△4				

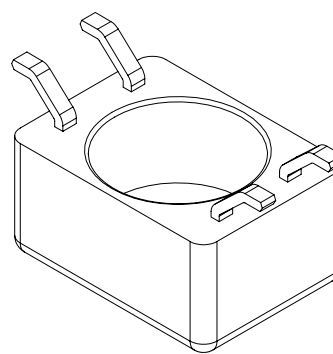
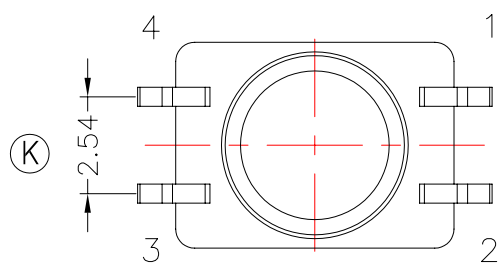
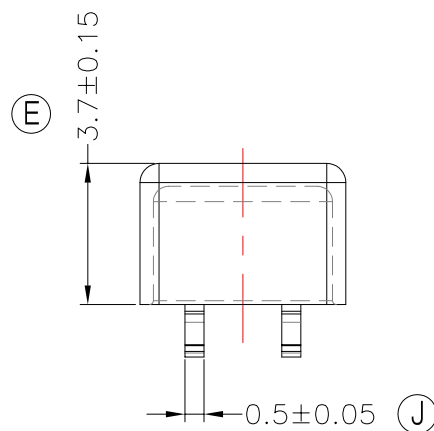
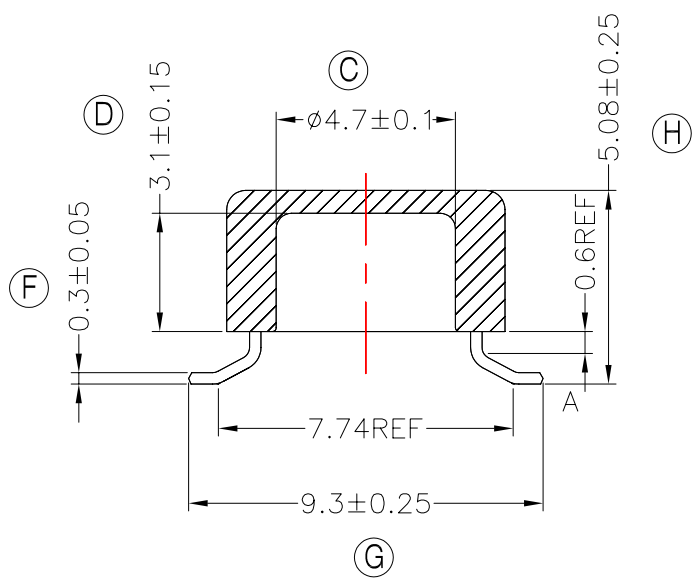
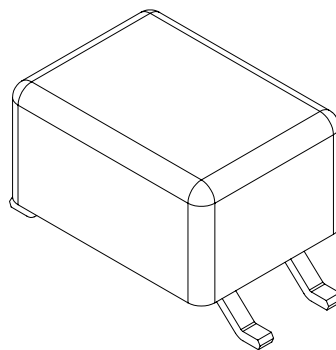
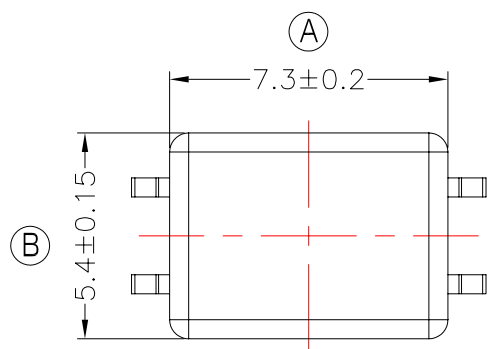

NOTE: CASE 頂部共面度為0.1 MAX.

DWG NO.	K5-4P-L-2.54-C-11				
PART NO.	MATERIAL (BOBBIN)	MATERIAL (TERMINAL)	TERMINAL (PLATING)	PIN ALLOCATION	NOTE
TBI-113-12031.1103	PM-9630	PB	Sn	ALL PIN	
	TOLERANCE: 0<L≤4:±0.1 4<L≤16:±0.2 16<L≤63:±0.3			UNIT : m / m	SCALE 5 : 1

Finish: 1. PB wire Immersion Sn on terminal : Thickness:Sn plating, 100,5 µm (200 µ inches) min, Base nickel 0.625 µm (25 µ inches) min.
 2. CP wire Immersion Sn on terminal : Thickness:Sn plating, 100,5 µm (200 µ inches) min.
 3. Coplanarity deviation: 0.08 mm (0.003 inches) max.

REV 1