

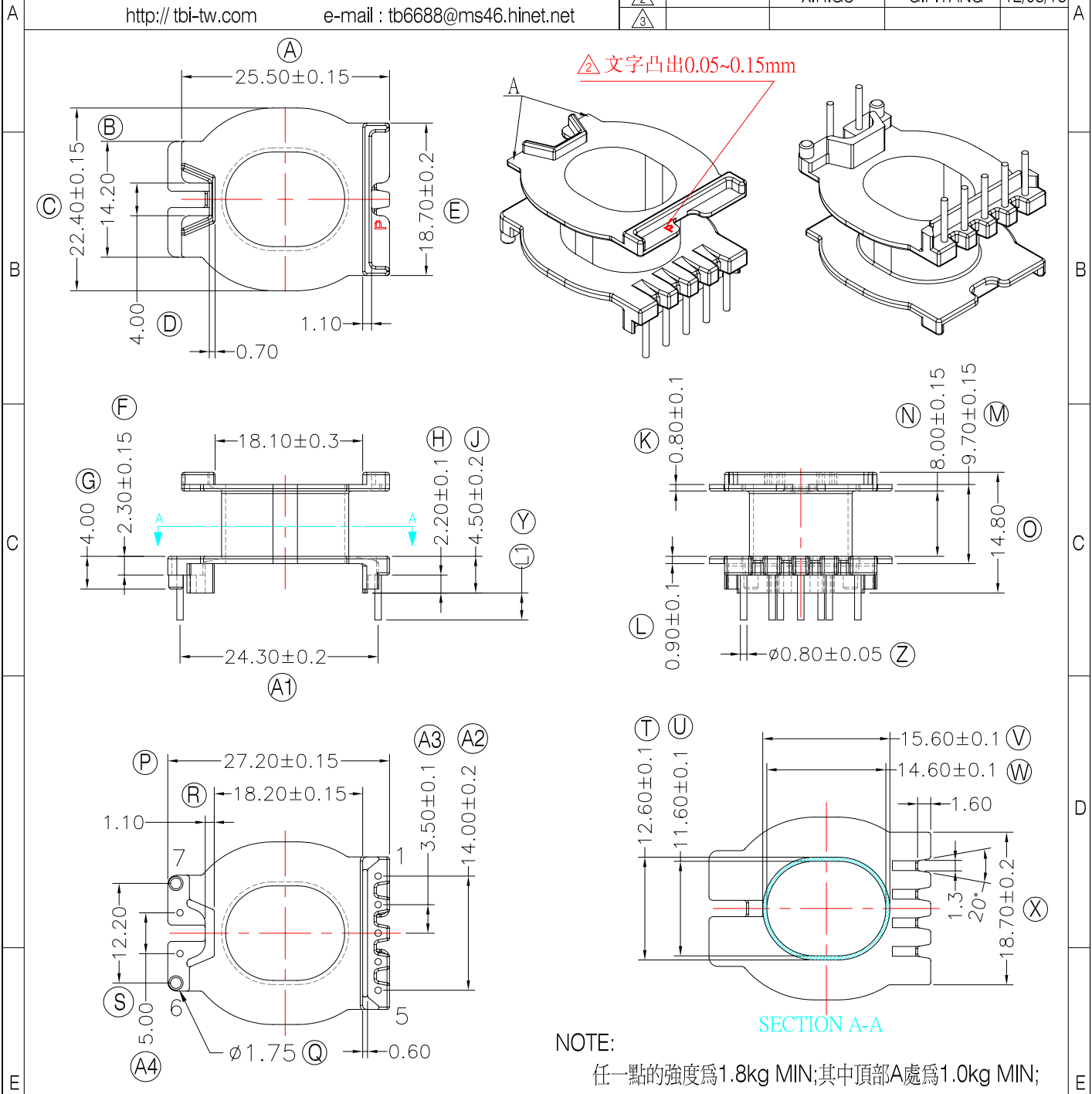

TRANSFORMER BOBBIN
INDUSTRIAL CO.,LTD.

Tel : 86-769-88789999 Fax : 86-769-88789989
http:// tbi-tw.com e-mail : tb6688@ms46.hinet.net

| REVISIONS | | | | |
|-----------|-----|---------|----------|----------|
| REV | SYM | DRAFTER | CHECKER | DATE |
| 1 | | X.H.GU | G.F.YANG | 08/20/12 |
| 2 | | X.H.GU | G.F.YANG | 12/03/16 |
| 3 | | | | |



NOTE:
任一點的強度為1.8kg MIN;其中頂部A處為1.0kg MIN;

| DWG NO. | ATQ27-16-1-7P-TH-G8-12 | | | | |
|--|------------------------|---------------------|--------------------|------------------------------|-------------|
| PART NO. | MATERIAL (BOBBIN) | MATERIAL (TERMINAL) | TERMINAL (PLATING) | PIN ALLOCATION | NOTE |
| TBI-238-03781.1206 | PM-9820 | CP WIRE | Sn | ALL PIN (L1) = 3.3±0.2 | S |
| TBI-238-03781.1216 | PM-9820 | CP WIRE | Sn | NO PIN #1,2,3 (L1) = 3.3±0.2 | H |
| TBI-238-03781.1226 | PM-9820 | CP WIRE | Sn | NO PIN #1,2,7 (L1) = 3.3±0.2 | |
| TBI-238-03781.1236 | PM-9820 | CP WIRE | Sn | NO PIN #3 (L1) = 4.0±0.3 | |
| TBI-238-03781.1246 | PM-9820 | CP WIRE | Sn | NO PIN #3 (L1) = 5.5±0.2 | |
| TBI-238-03781.1256 | PM-9820 | CP WIRE | Sn | CUT PIN#3 (L1) = 3.6±0.2 | |
| TBI-238-03781.1266 | PM-9820 | CP WIRE | Sn | NO PIN #1,3,5 (L1) = 3.3±0.2 | |
| TBI-238-03781.1276 | PM-9820 | CP WIRE | Sn | NO PIN #1,3,5 (L1) = 4.0±0.2 | |
| TBI-238-03781.1286 | PM-9820 | CP WIRE | Sn | NO PIN #1,3,5 (L1) = 3.0±0.2 | |
| TBI-238-03781.1296 | PM-9820 | CP WIRE | Sn | NO PIN #1,2,7 (L1) = 5.5±0.2 | |
| TOLERANCE: 0<L<=4±0.1 4<L<=16±0.2 16<L<=63±0.3 | | | | UNIT : m / m | SCALE 1 : 1 |

Finish: 1. PB wire Immersion Sn on terminal : Thickness:Sn plating,100,5μm (200μ inches) min,Base nickel 0.625μm (25μ inches) min.
2. CP wire Immersion Sn on terminal : Thickness:Sn plating,100,5μm (200μ inches) min.
3. Coplanarity deviation: 0.10 mm (0.004 inches) max.

| | |
|-----|---|
| REV | 2 |
|-----|---|

A-CORE

A-CORE JIANGMEN ELECTRONICS CO.,LTD
 江門安磁電子有限公司

TBI

TRANSFORMER BOBBIN
 INDUSTRIAL CO.,LTD.

ELECTRICAL CO. Tel : 86-750-3867791 Fax : 86-750-3867787

Tel : 86-769-88789999 Fax : 86-769-88789989

e-mail : sales@acore-ferrite.com

http:// tbi-tw.com e-mail : tb6688@ms46.hinet.net

REVISIONS

| REV | SYM | DRAFTER | CHECKER | DATE |
|-----|-----|---------|----------|----------|
| △1 | | X.H.GU | G.F.YANG | 08/20/12 |
| △2 | | X.H.GU | G.F.YANG | 12/03/16 |
| △3 | | | | |

TOP

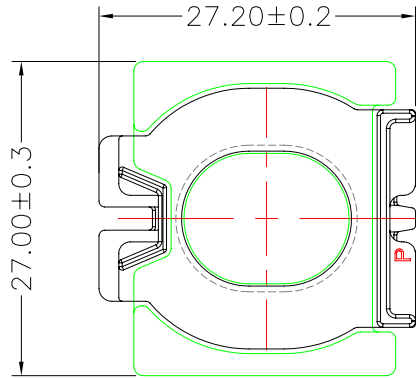

TOP

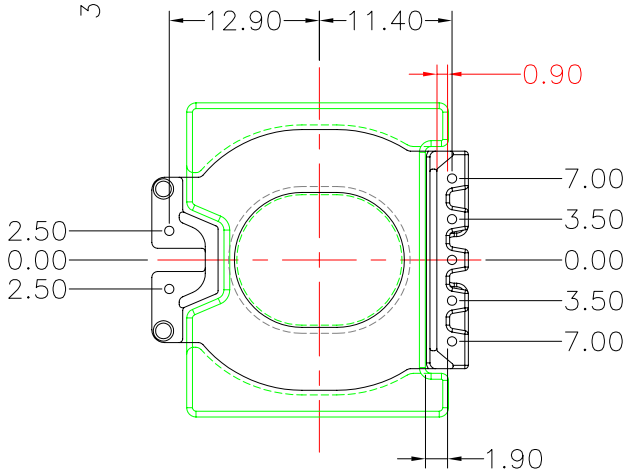
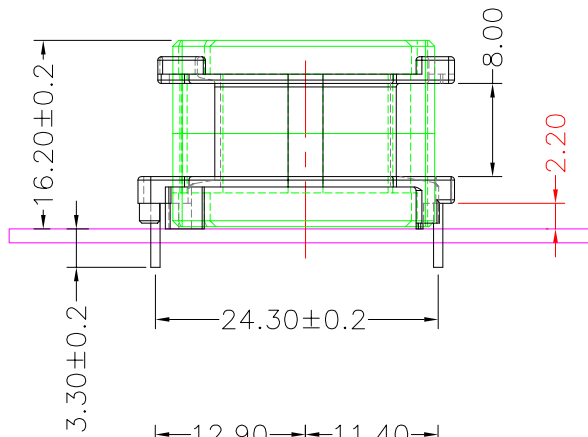
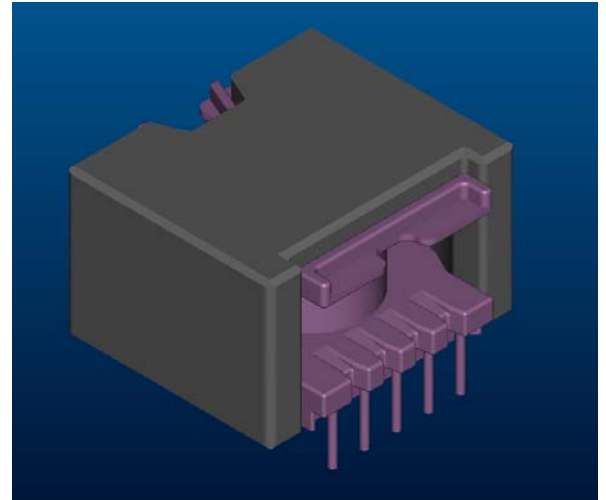

BOTTOM

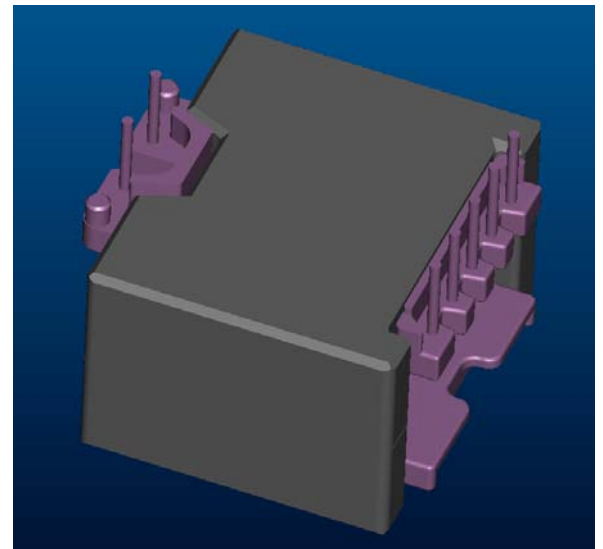

| ITEM | PART NO. | MATERIAL | DWG NO. | Core Set Parameters |
|--------|--------------------|----------|------------------------|--|
| CORE | ATQ27/16-1 | JPP-44A | | Ae=129mm ² Le=47.5mm C1=0.368mm ⁻¹ Ve=6127.5mm ³ |
| CORE | ATQ27/16-1 | JPP-95 | | |
| BOBBIN | TBI-238-03781.12XX | | ATQ27-16-1-7P-TH-G8-12 | |
| | | | | |

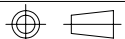

UNIT : m/m

SCALE 1 : 1

REV 2