

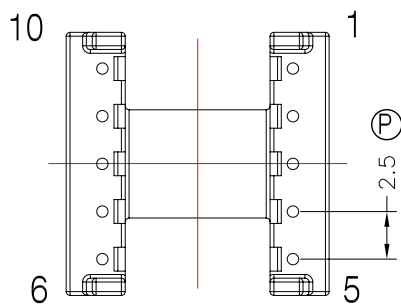

TRANSFORMER BOBBIN  
INDUSTRIAL CO.,LTD.

Tel : 86-769-88789999 Fax : 86-769-88789989  
http:// tbi-tw.com e-mail : tb6688@ms46.hinet.net

REVISIONS				
REV	SYM	DRAFTER	CHECKER	DATE
①		YAN.TANG	G.F.YANG	12/10/08
②		YAN.TANG	G.F.YANG	07/20/10
③		X.H.GU	G.F.YANG	04/16/19

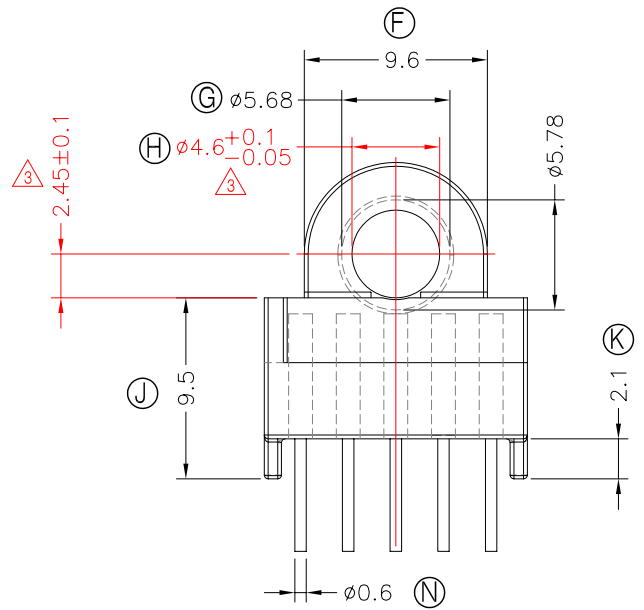
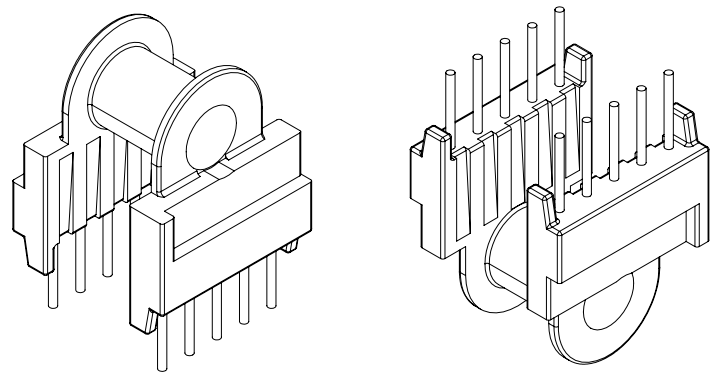
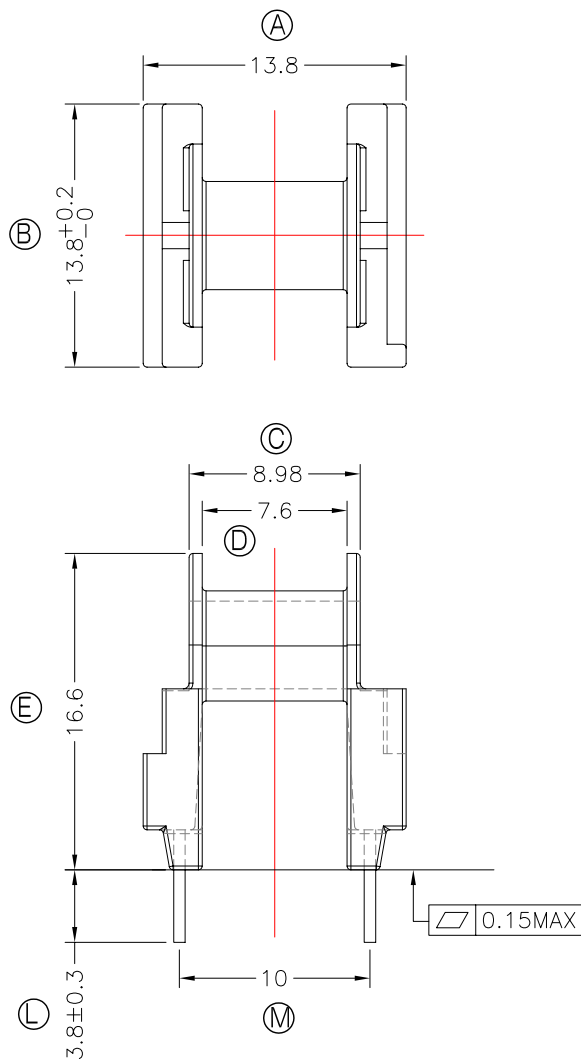

NOTE:

1. 拉力:1.0KG MIN,焊錫後拉力:1.5Kg Min;
2. 平整度要求為0.15mm MAX ;
3. 繞線管毛邊0.05 MAX ,其它處毛邊0.1 MAX;

DWG NO.	EP13-10P-TH-2.5-A0-11						
PART NO.	MATERIAL (BOBBIN)	MATERIAL (TERMINAL)	TERMINAL (PLATING)	PIN ALLOCATION	NOTE		
TBI-203-03101.1106	PM-9630	C.P WIRE	Sn	ALL PIN	52GEP1310P06	S	
TBI-203-03101.1116	PM-9630	C.P WIRE	Sn	NO PIN#8		H	
TBI-203-03101.1126	PM-9630	C.P WIRE	Sn	NO PIN#1			
TBI-203-03101.1136	PM-9630	C.P WIRE	Sn	NO PIN#2,7,8,9			
TBI-203-03101.1146	PM-9630	C.P WIRE	Sn	NO PIN#4,7,8,9			
TBI-203-03101.1156	PM-9630	C.P WIRE	Sn	NO PIN #1,5			
	TOLERANCE:0<L<=4:±0.1 4<L<=16:±0.2 16<L<=30:±0.3 30<L<=50:±0.4 50<L:±0.5			UNIT : m / m	SCALE 1 : 1		
Finish:	1. PB wire Immersion Sn on terminal : Thickness:Sn plating,100,5 μm (200 μ inches) min,Base nickel 0.625 μm (25 μ inches) min. 2. CP wire Immersion Sn on terminal : Thickness:Sn plating,100,5 μm (200 μ inches) min. 3. Coplanarity deviation: 0.10 mm (0.004 inches) max.					REV	3