



**TRANSFORMER BOBBIN
INDUSTRIAL CO.,LTD.**

Tel : 86-769-88789999 Fax : 86-769-88789999
http:// tbi-tw.com e-mail : tb6688@ms46.hinet.net

REVISIONS

REV	SYM	DRAFTER	CHECKER	DATE
1		G.F.YANG	W.H.HSU	12/05/08
2		G.F.YANG	W.H.HSU	12/05/08
3		G.F.YANG	W.H.HSU	12/17/08

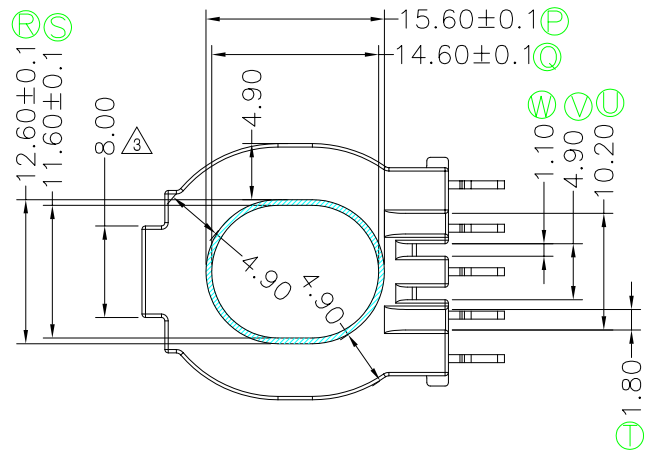
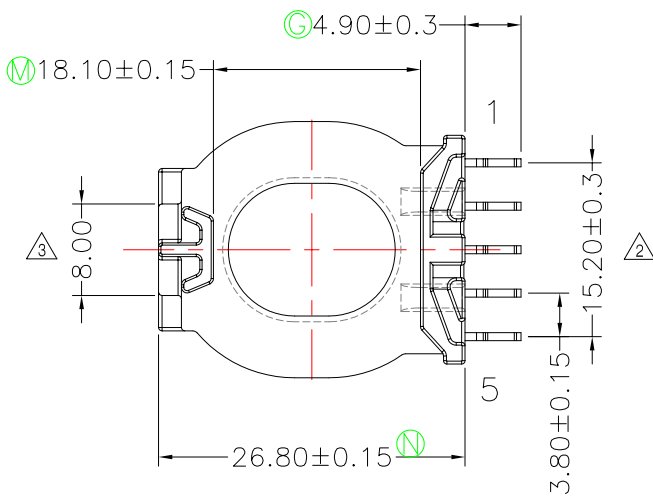
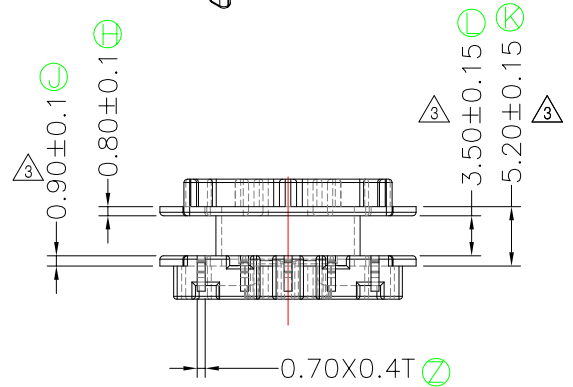
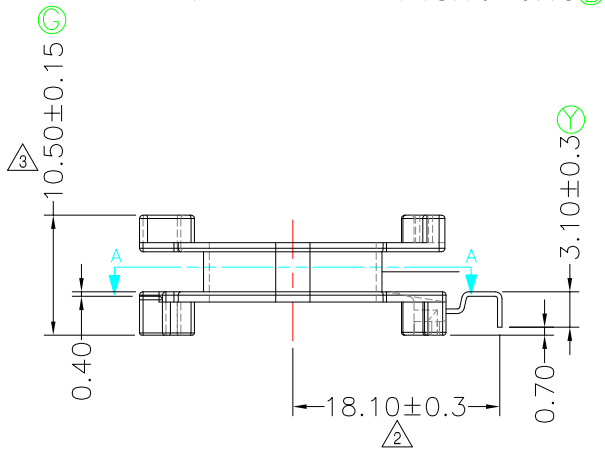
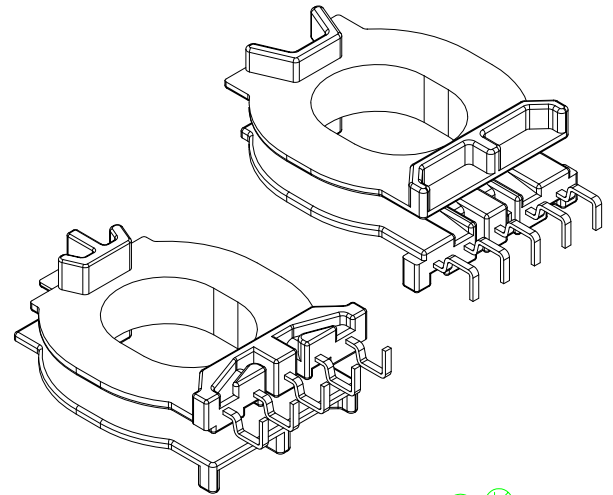
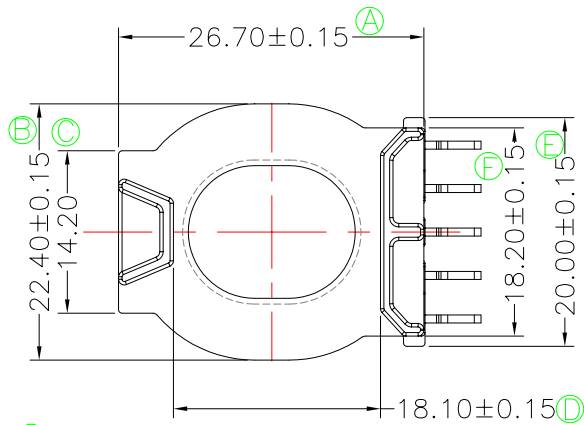

SECTION A-A

DWG NO. ATQ27-11.6-5P-THT-A-11

PART NO.	MATERIAL (BOBBIN)	MATERIAL (TERMINAL)	TERMINAL (PLATING)	PIN ALLOCATION	NOTE
TBI-238-03011.1106	PM-9630	C.P WIRE	Sn	ALL PIN	

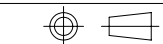

TOLERANCE: .XX±0.2 .XXX±0.1

UNIT : m / m

SCALE 1 : 1

Finish: 1. Pb wire Immersion Sn on terminal : Thickness:Sn plating,100,5 μm (200 μ inches) min,Base nickel 0.625 μm (25 μ inches) min.
2. CP wire Immersion Sn on terminal : Thickness:Sn plating,100,5 μm (200 μ inches) min.
3. Coplanarity deviation: 0.10 mm (0.004 inches) max.

REV 3

A-CORE

A-CORE JIANGMEN ELECTRONICS CO.,LTD
 江門安磁電子有限公司

TBI

TRANSFORMER BOBBIN
 INDUSTRIAL CO.,LTD.

ELECTRICAL CO. Tel : 86-750-3867791 Fax : 86-750-3867787
 e-mail : sales@acore-ferrite.com

Tel : 86-769-88789999 Fax : 86-769-88789989
 http:// tbi-tw.com e-mail : tb6688@ms46.hinet.net

REVISIONS

REV	SYM	DRAFTER	CHECKER	DATE
△1		G.F.YANG	W.H.HSU	12/05/08
△2		G.F.YANG	W.H.HSU	12/05/08
△3		G.F.YANG	W.H.HSU	12/17/08

TOP

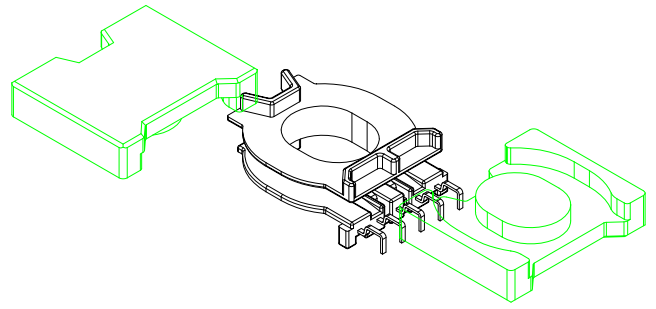
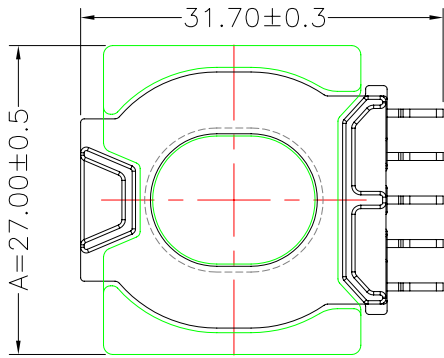

TOP

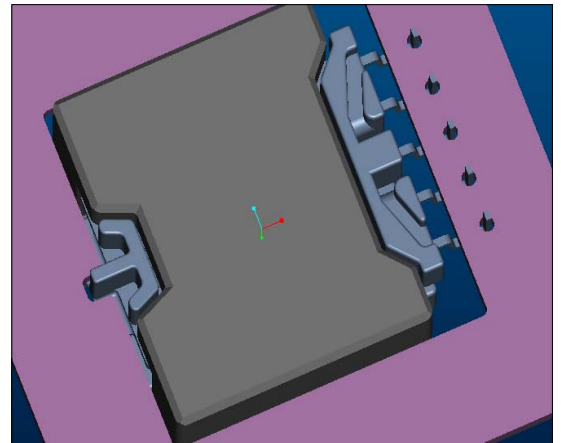
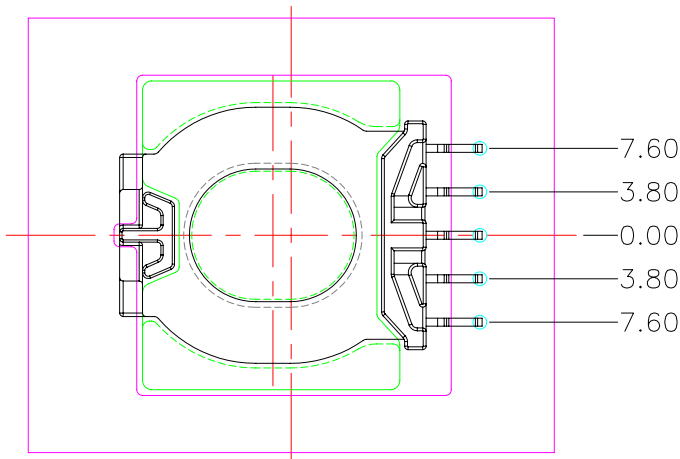
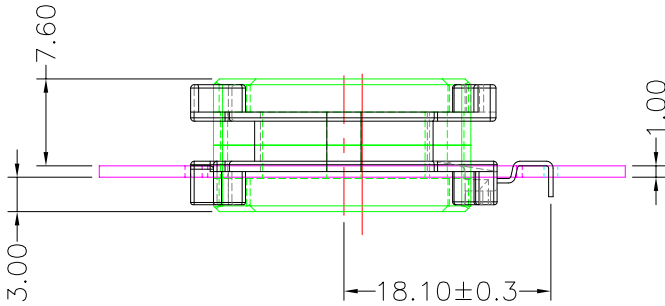
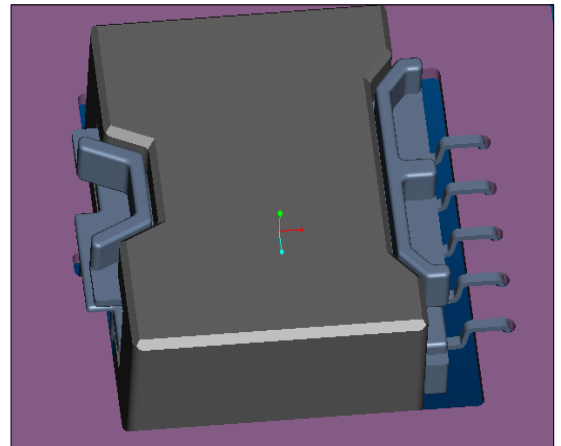

BOTTOM

BOTTOM

ITEM	PART NO.	MATERIAL	DWG NO.	Core Set Parameters
CORE	ATQ27/11.6	JPP-44A		Ae=131.4mm ² Le=38.1mm C1=0.290mm ⁻¹ Ve=5006.34mm ³
CORE	ATQ27/11.6	JPP-95		
BOBBIN	TBI-238-03011.11XX		ATQ27-11.6-5P-THT-A-11	

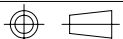

UNIT : m/m

SCALE 1 : 1

REV 3