

A-CORE
ELECTRICAL CO.

A-CORE JIANGMEN ELECTRONICS CO.,LTD
 江门安磁电子有限公司
 Tel: 86-750-3867791 Fax : 86-750-3867787

REVISIONS				
REV	SYM	DRAFTER	CHECKER	DATE
1		S.Y.TANG	G.F.YANG	12/20/08
2				
3				

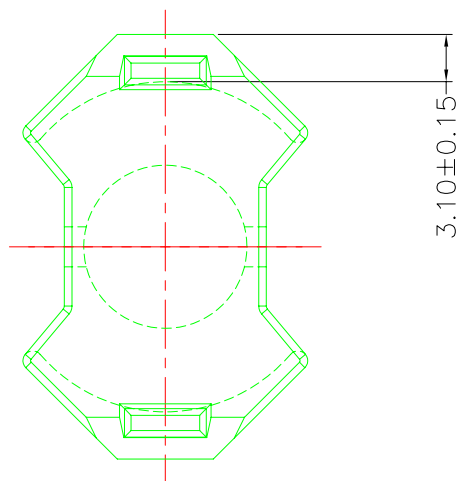
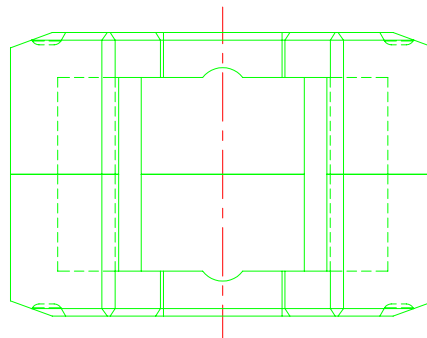
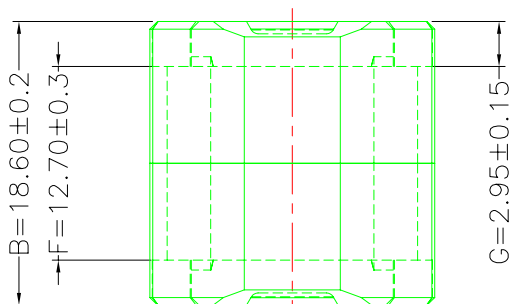
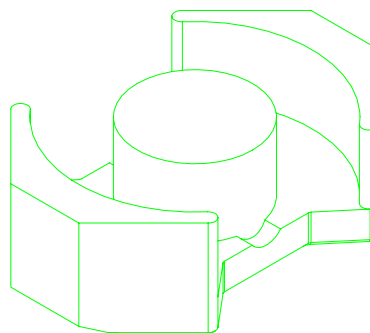
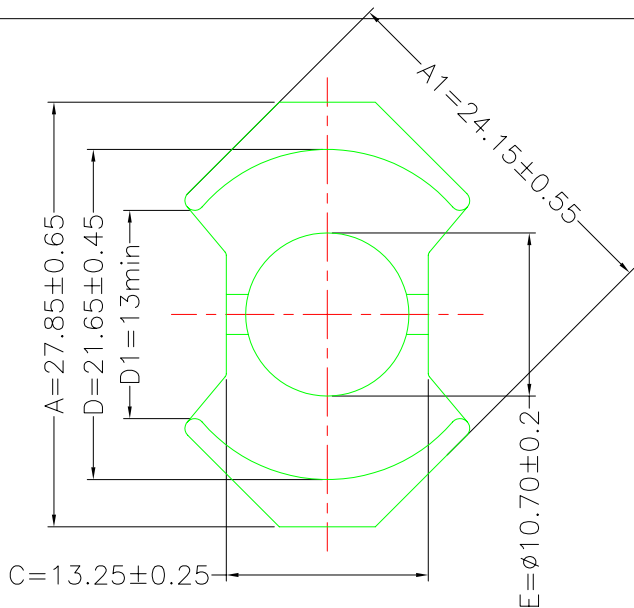

Core Set Parameters

$A_e=98\text{mm}^2$

$L_e=44\text{mm}$

$C_l=0.449\text{mm}^{-1}$

$V_e=4312\text{mm}^3$

DWG NO.	RM10/18.6 CORE				
PART NO.	MATERIAL (BOBBIN)	MATERIAL (TERMINAL)	TERMINAL (PLATING)	PIN ALLOCATION	NOTE
RM10/18.6	JPP-44A				
RM10/18.6	JPP-95				

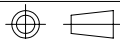

Finish:

UNIT : m/m

SCALE 1 : 1

REV 1

A-CORE

A-CORE JIANGMEN ELECTRONICS CO.,LTD
江門安磁電子有限公司

TBI

TRANSFORMER BOBBIN
INDUSTRIAL CO.,LTD.

ELECTRICAL CO. Tel : 86-750-3867791 Fax : 86-750-3867787

Tel : 86-769-88789999 Fax : 86-769-88789989

e-mail : sales@acore-ferrite.com

http:// tbi-tw.com e-mail : tb6688@ms46.hinet.net

REVISIONS

REV	SYM	DRAFTER	CHECKER	DATE
△1		X.H.GU	G.F.YANG	07/09/11
△2				
△3				

TOP

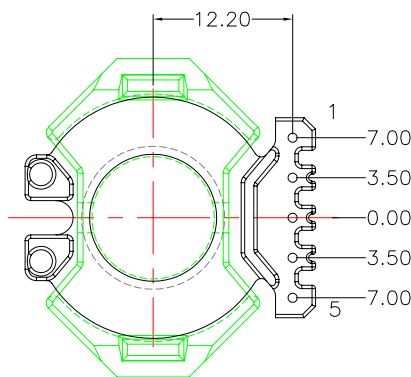
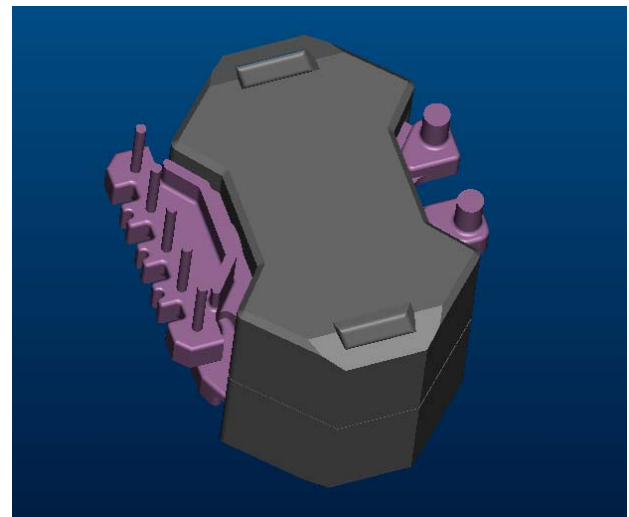
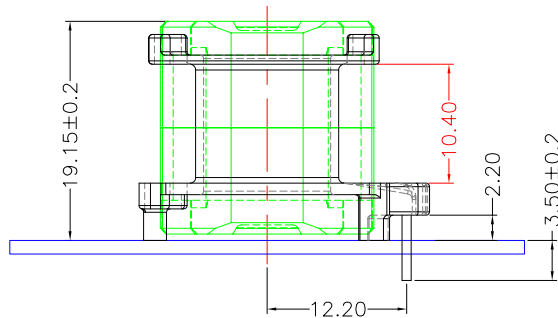
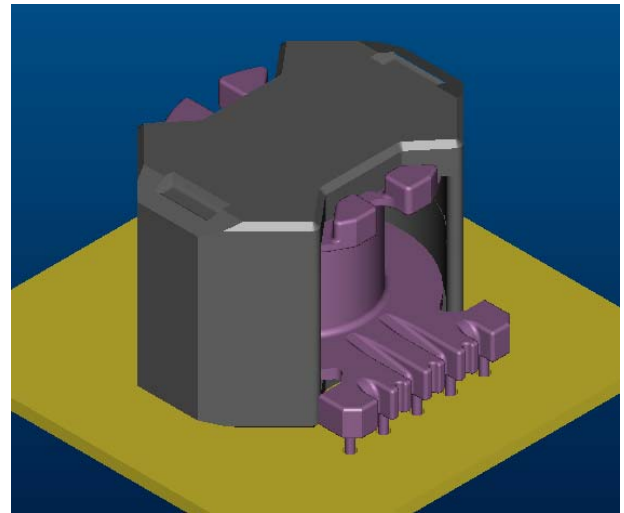
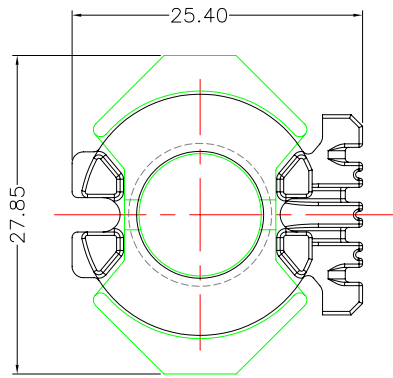

BOTTOM

BOTTOM

ITEM	PART NO.	MATERIAL	DWG NO.	Core Set Parameters
CORE	RM10/18.6	JPP-44A		$A_e=98\text{mm}^2$ $L_e=44\text{mm}$ $C_1=0.449\text{mm}^{-1}$ $V_e=4312\text{mm}^3$
CORE	RM10/18.6	JPP-95		
BOBBIN	TBI-208-04321.12XX		RM10-18.6-5P-TH-C2-12	

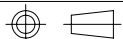

UNIT : m / m

SCALE 1 : 1

REV 2