





**A-CORE**

A-CORE JIANGMEN ELECTRONICS CO.,LTD  
江門安磁電子有限公司

**TBI**

TRANSFORMER BOBBIN  
INDUSTRIAL CO.,LTD.

ELECTRICAL CO. Tel : 86-750-3867791 Fax : 86-750-3867787

Tel : 86-769-88789999 Fax : 86-769-88789989

e-mail : sales@acore-ferrite.com

http:// tbi-tw.com e-mail : tb6688@ms46.hinet.net

REVISIONS

REV	SYM	DRAFTER	CHECKER	DATE
△2		X.H.GU	G.F.YANG	07/16/10
△3		X.H.GU	G.F.YANG	10/29/10
△4		X.H.GU	G.F.YANG	01/06/11

TOP

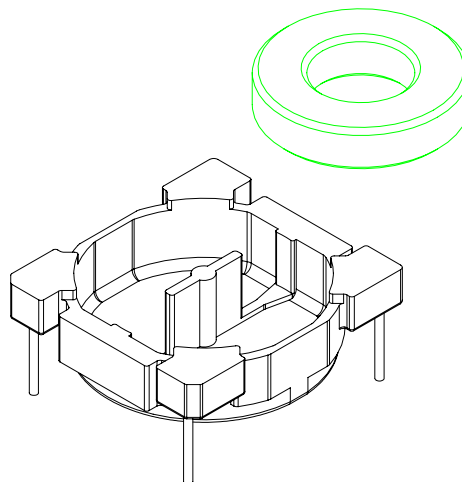
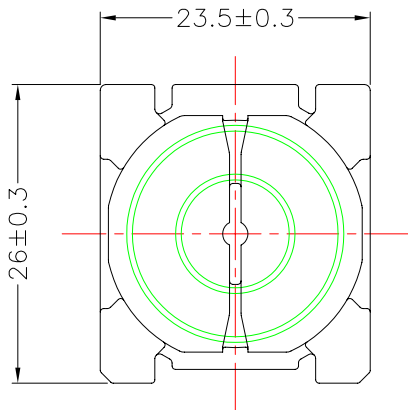

TOP

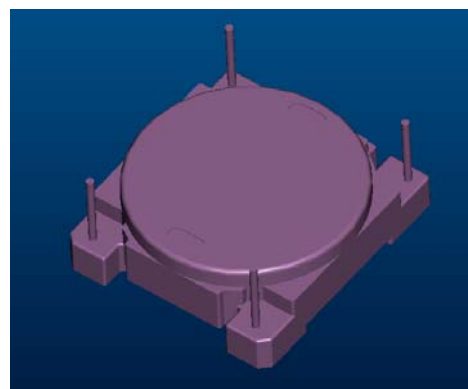
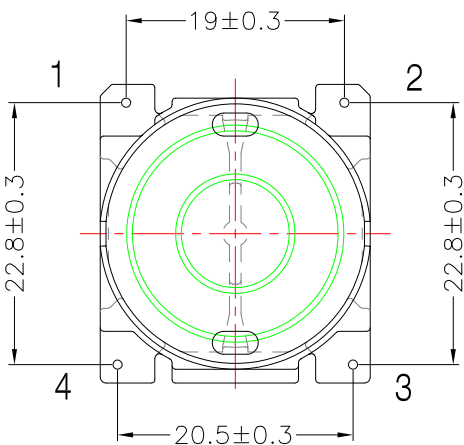
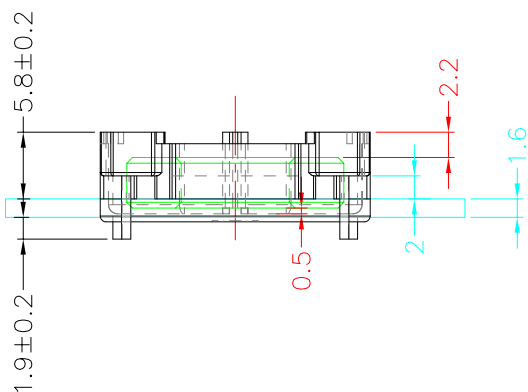

BOTTOM

BOTTOM

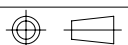
ITEM	PART NO.	MATERIAL	DWG NO.	Core Set Parameters
CORE	OR18.5X4-9.8C	JPH-10F		$A_e=16.8\text{mm}^2$ $L_e=41.6\text{mm}$ $C_1=2.47\text{mm}^{-1}$ $V_e=698.88\text{mm}^3$
BASE	TBI-220-16221.12XX		OR18.5X4-9.8C-BASE-B2-12	
				UNIT : m/m
				SCALE 1 : 1
				REV 4