

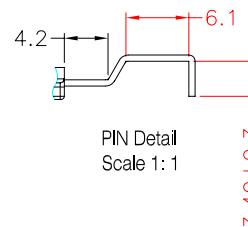

**TRANSFORMER BOBBIN  
INDUSTRIAL CO.,LTD.**

Tel : 86-769-88789999 Fax : 86-769-88789999  
http:// tbi-tw.com e-mail : tb6688@ms46.hinet.net

REVISIONS				
REV	SYM	DRAFTER	CHECKER	DATE
1		G.F.YANG	W.H.HSU	10/08/10
2		X.H.GU	G.F.YANG	01/10/11
3				

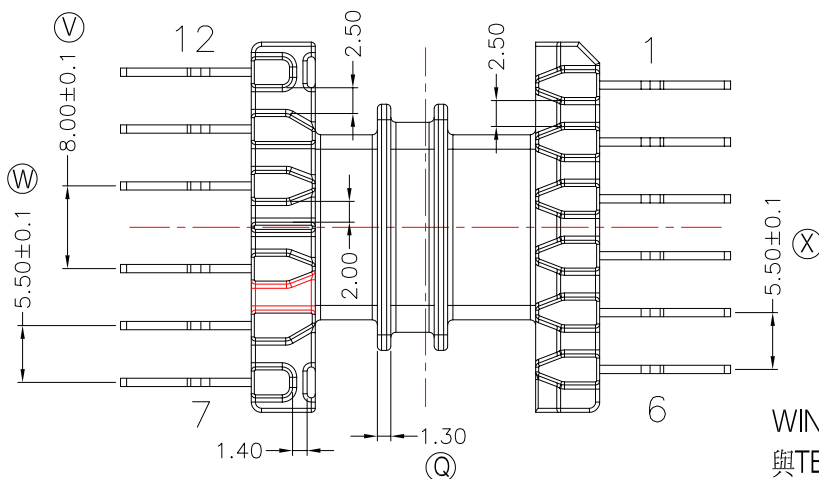
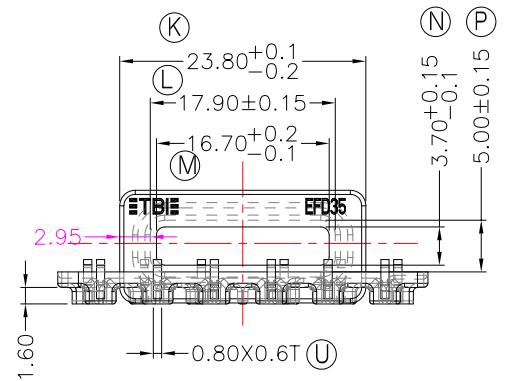
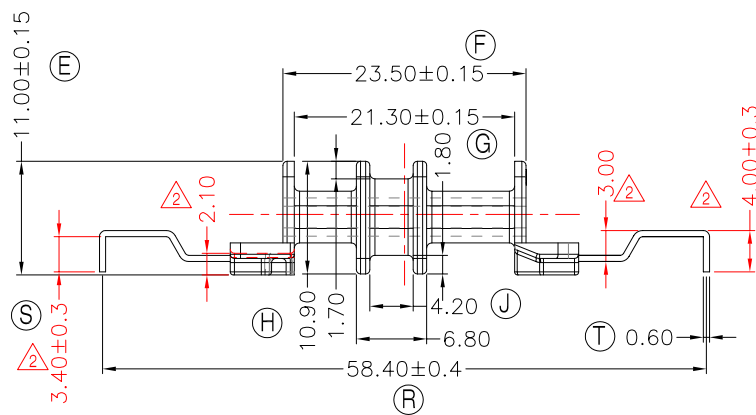
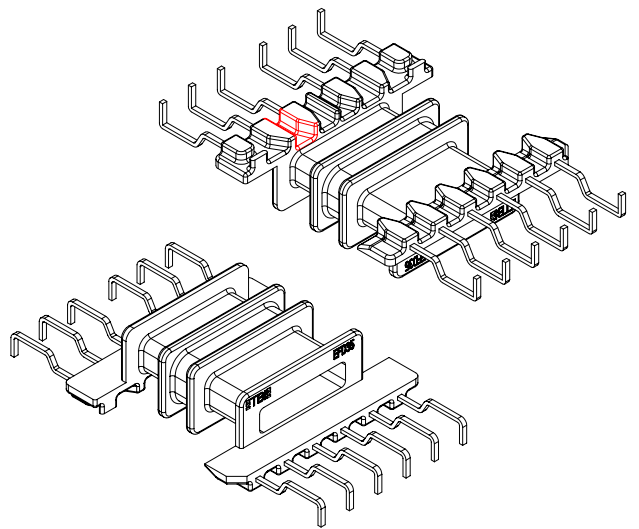
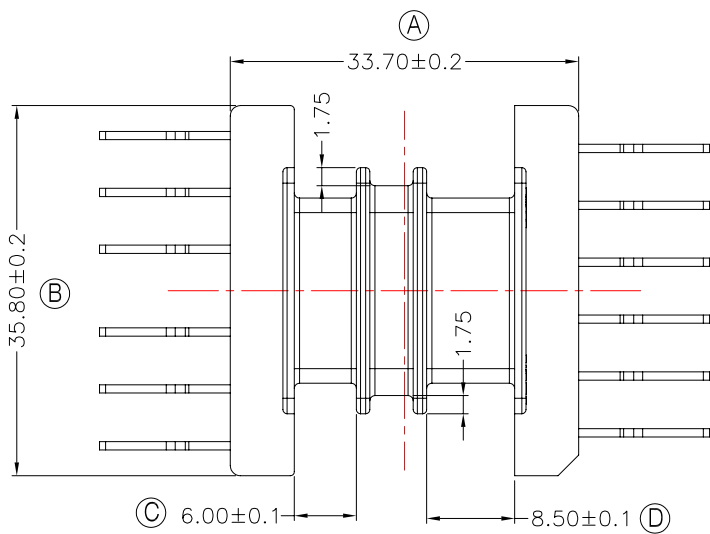

焊錫前拉力:1.0KG MIN  
焊錫後拉力:1.5KG MIN  
任意一點強度須3.0kg MIN;

WINDING SPACE: (6.0+8.5)\*2.95mm=42.78mm<sup>2</sup>  
與TBI-207-21091.91C(EFD3535B-CASE-0J-91)配套使用;

DWG NO. EFD3535B-12P-THT-0J-11

PART NO. MATERIAL (BOBBIN) MATERIAL (TERMINAL) TERMINAL (PLATING) PIN ALLOCATION NOTE

TBI-207-21091.1106 PM-9630 CP WIRE Sn ALL PIN S

H

TOLERANCE: 0<L<=4: ±0.1 4<L<=16: ±0.2 16<L<=63: ±0.3

UNIT : m / m

SCALE 1 : 1

Finish: 1. PB wire Immersion Sn on terminal : Thickness:Sn plating,100,5 μm (200 μ inches) min,Base nickel 0.625 μm (25 μ inches) min.  
2. CP wire Immersion Sn on terminal : Thickness:Sn plating,100,5 μm (200 μ inches) min.  
3. Coplanarity deviation: 0.10 mm (0.004 inches) max.

REV 2





**A-CORE**

A-CORE JIANGMEN ELECTRONICS CO.,LTD  
 江門安磁電子有限公司

**TBI**

TRANSFORMER BOBBIN  
 INDUSTRIAL CO.,LTD.

ELECTRICAL CO. Tel : 86-750-3867791 Fax : 86-750-3867787

Tel : 86-769-88789999 Fax : 86-769-88789989

e-mail : sales@acore-ferrite.com

http:// tbi-tw.com e-mail : tb6688@ms46.hinet.net

REVISIONS

REV	SYM	DRAFTER	CHECKER	DATE
△		G.F.YANG	W.H.HSU	10/08/10
△		X.H.GU	G.F.YANG	01/07/11
△				

TOP

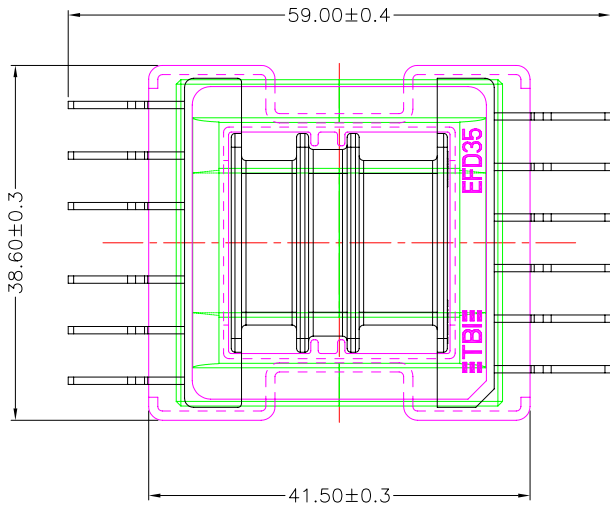

TOP

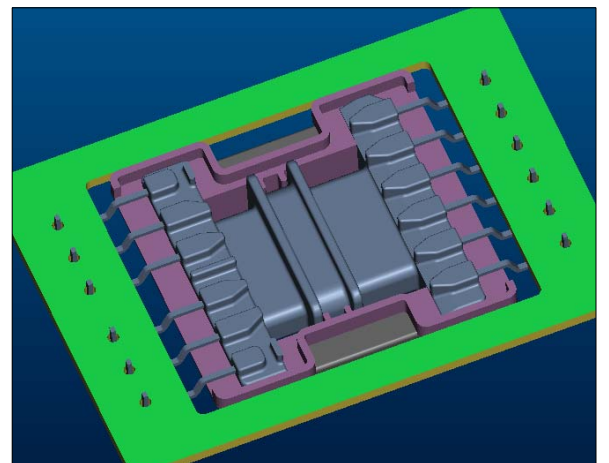
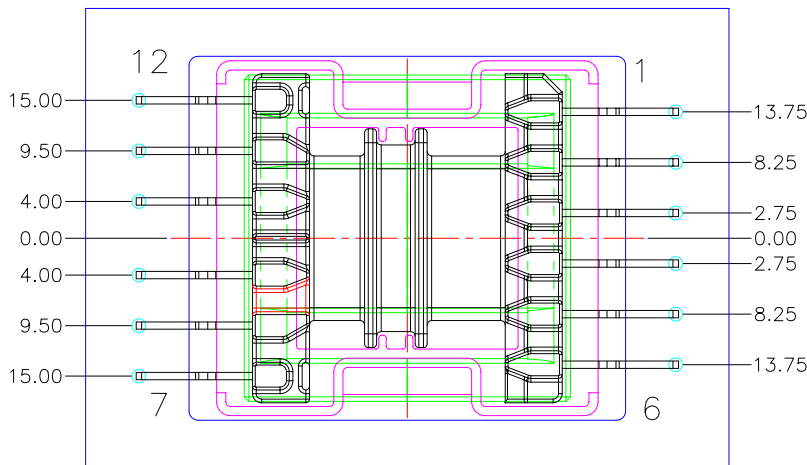
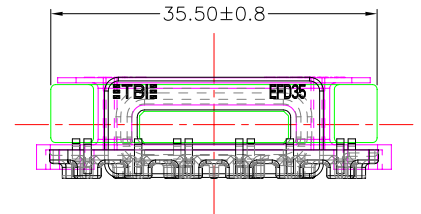
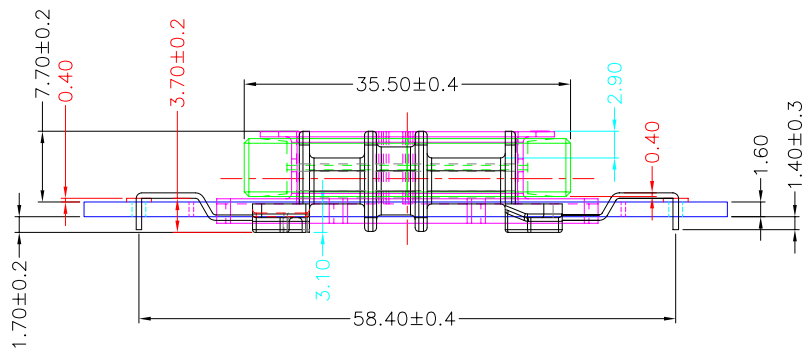
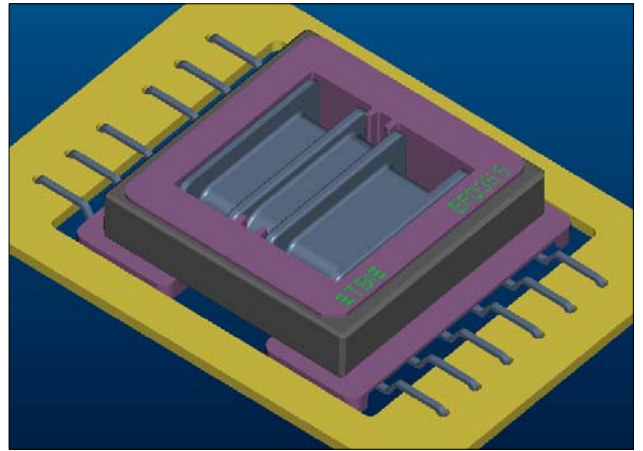

BOTTOM

BOTTOM

ITEM	PART NO.	MATERIAL	DWG NO.	Core Set Parameters
CORE	EFD35/35B	JPP-44A		Ae=57.1mm <sup>2</sup> Le=80.1mm C1=1.403mm <sup>-1</sup> Ve=4573.71mm <sup>3</sup>
CORE	EFD35/35B	JPP-95		
BOBBIN	TBI-207-21091.11XX		EFD3535B-12P-THT-0J-11	
CASE	TBI-207-21091.91C		EFD3535B-CASE-0J-91	

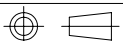

UNIT : m/m

SCALE 1 : 1

REV 2