



**TRANSFORMER BOBBIN INDUSTRIAL CO.,LTD.**

Tel : 86-769-88789999 Fax : 86-769-88789989  
 http:// tbi-tw.com e-mail : tb6688@ms46.hinet.net

REVISIONS

REV	SYM	DRAFTER	CHECKER	DATE
△0		Y.G.HSU	W.H.HSU	06/07/07
△1		YAN.TANG	W.H.HSU	06/14/07
△2		YAN.TANG	W.H.HSU	08/16/07

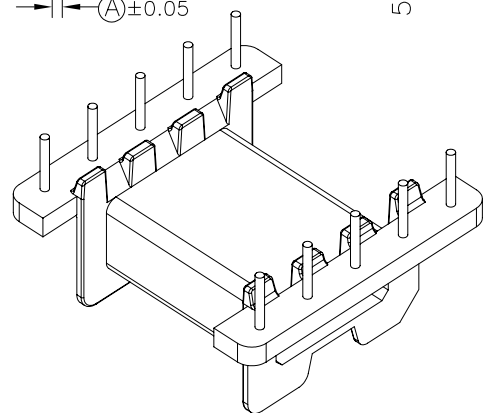
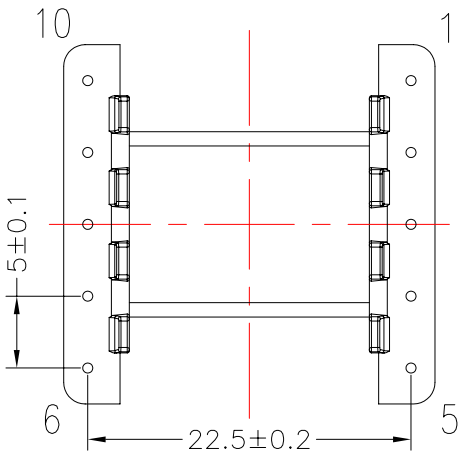
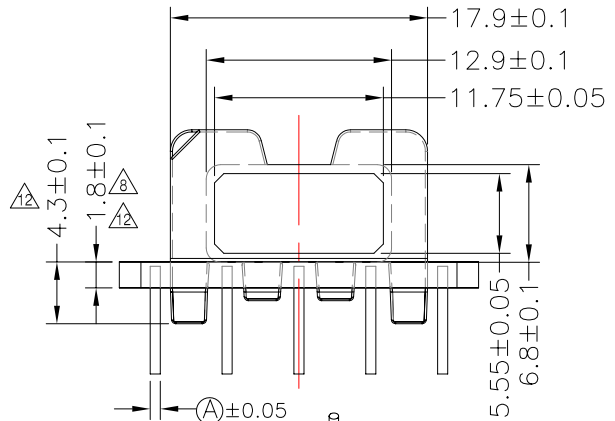
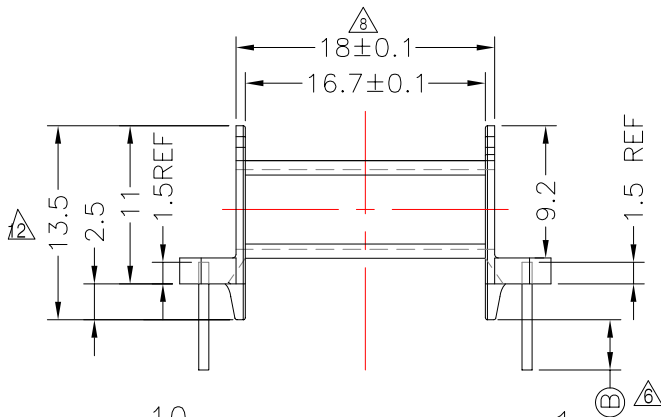
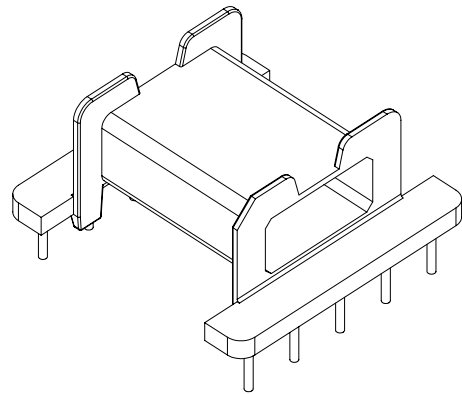
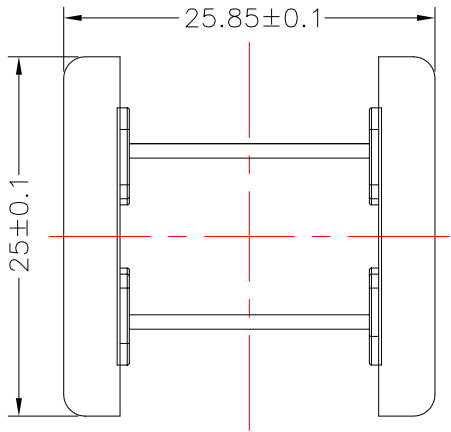

塑件本體共面度請參考圖框下"備註3"

DWG NO.	EFD25-10P-TH-5-A-1				
PART NO.	MATERIAL (BOBBIN)	MATERIAL (TERMINAL)	TERMINAL (PLATING)	PIN ALLOCATION	NOTE
TBI-207-02011.106	PM-9630	CP WIRE	Sn	ALL PIN (A)= $\phi$ 0.7 (B)= $3.5\pm 0.3$	
TBI-207-02011.116	PM-9630	CP WIRE	Sn △6	ALL PIN (A)=SQ 0.55 (B)= $2.9\pm 0.2$	15-1013-00
TBI-207-02011.126	PM-9630	CP WIRE	Sn △6	CUT PIN 5,6 (A)=SQ 0.55 (B)= $2.9\pm 0.3$	15-1013-01
△9 TBI-207-02011.136	PM-9630	CP WIRE	Sn	ALL PIN (A)=SQ 0.6 (B)= $3.5\pm 0.3$	
△10 TBI-207-02011.146	PM-9630	CP WIRE	Sn	ALL PIN (A)= $\phi$ 0.7 (B)= $5.0\pm 0.3$	
△11 TBI-207-02011.156	PM-9630	CP WIRE	Sn	CUT PIN #1 (A)=SQ0.6 (B)= $3.05\pm 0.25$	MG515-00122
F TBI-207-02011.166	PM-9630	CP WIRE	Sn	ALL PIN (A)= $\phi$ 0.7 (B)= $3.5+0.5/-0$	
TBI-207-02011.176	PM-9630	CP WIRE	Sn	CUT PIN#3 (A)= $\phi$ 0.7 (B)= $3.5\pm 0.3$	
△12 TBI-207-02011.186	PM-9630	CP WIRE	Sn	ALL PIN (A)= $\phi$ 0.7 (B)= $4.0\pm 0.3$	
△12 TBI-207-02011.196	PM-9630	CP WIRE	Sn	ALL PIN (A)=SQ 0.6 (B)= $2.5\pm 0.2$	
TBI-207-02011.1A6	PM-9630	CP WIRE	Sn	ALL PIN (A)= $\phi$ 0.7 (B)= $5.5\pm 0.3$	暫無刀模
TBI-207-02011.1B6	PM-9630	CP WIRE	Sn	CUT PIN#4 (A)= $\phi$ 0.7 (B)= $3.5\pm 0.3$	
⊕	TOLERANCE: .X±0.15 .XX±0.10 .XXX±0.05			UNIT : m / m	SCALE 2 : 1

Finish: 1. PB wire Immersion Sn on terminal : Thickness: Sn plating, 100%, 5  $\mu$  m (200  $\mu$  inches) min, Base nickel 0.625  $\mu$  m (25  $\mu$  inches) min.  
 2. CP wire Immersion Sn on terminal : Thickness: Sn plating, 100%, 5  $\mu$  m (200  $\mu$  inches) min.  
 3. Coplanarity deviation: 0.10 mm (0.004 inches) max.

REV 12