



TRANSFORMER BOBBIN  
INDUSTRIAL CO.,LTD.

Tel : 86-769-88789999 Fax : 86-769-88789989  
http:// tbi-tw.com e-mail : tb6688@ms46.hinet.net

REVISIONS

REV	SYM	DRAFTER	CHECKER	DATE
1		X.H.GU	G.F.YANG	10/24/16
2				
3				

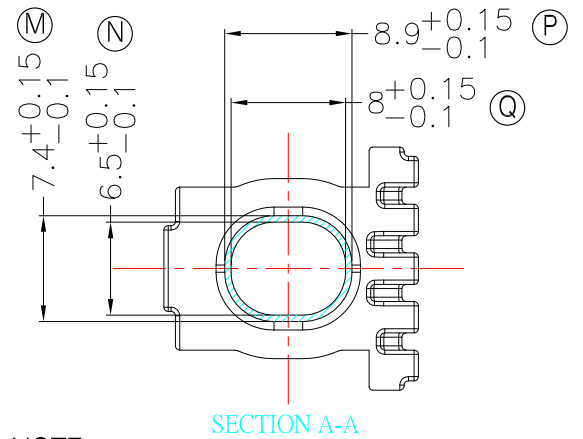
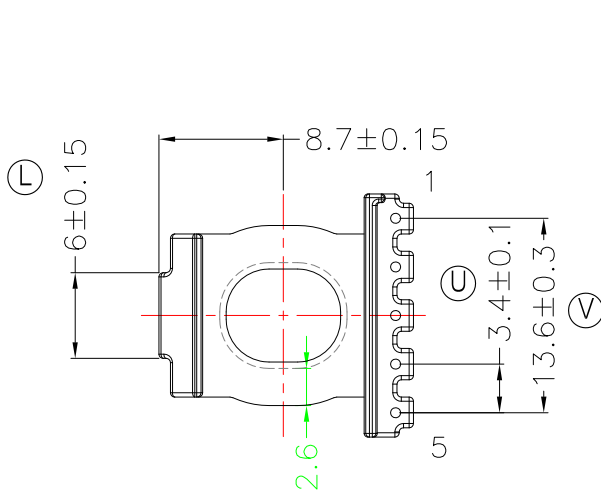
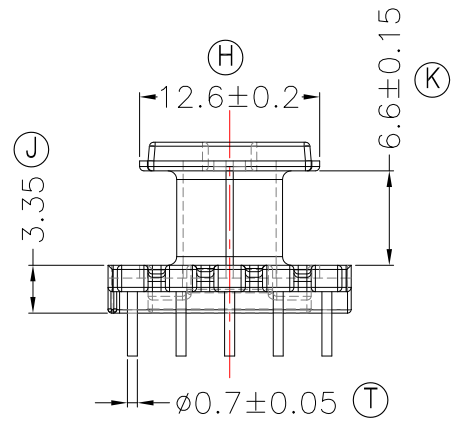
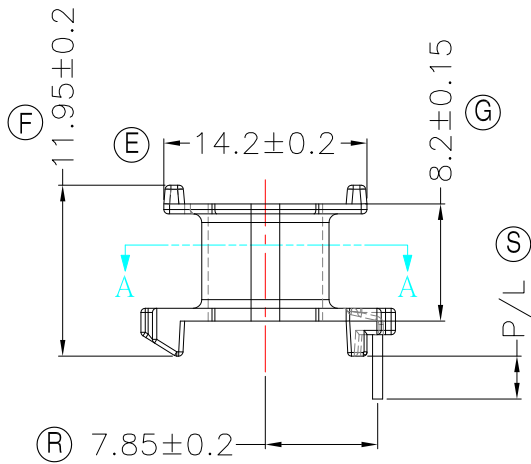
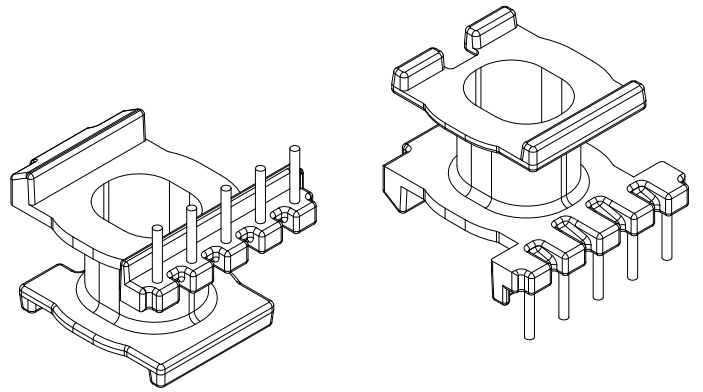
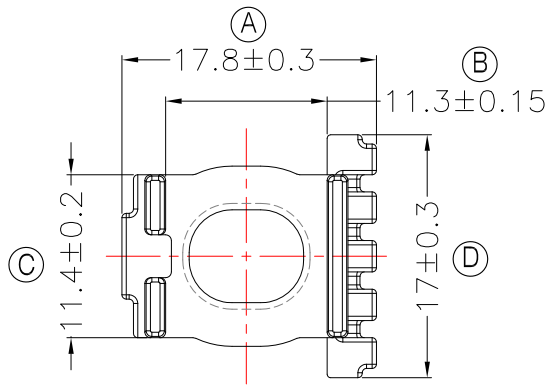

NOTE:  
WINDING SPACE: 6.6mm\*2.6mm=17.16mm<sup>2</sup>

DWG NO. ATQ17-12.4A-5P-TH-A-11

PART NO.	MATERIAL (BOBBIN)	MATERIAL (TERMINAL)	TERMINAL (PLATING)	PIN ALLOCATION	NOTE
TBI-238-26011.1106	PM-9630	CP WIRE	Sn	ALL PIN P/L=3.0±0.2	S
TBI-238-26011.1116	PM-9630	CP WIRE	Sn	ALL PIN P/L=3.5±0.2	H

TOLERANCE: 0<L<=4:±0.1 4<L<=16:±0.2 16<L<=63:±0.3

UNIT : m / m

SCALE 1 : 1

Finish: 1. PB wire Immersion Sn on terminal : Thickness:Sn plating,100%,5 μm (200 μ inches) min,Base nickel 0.625 μm (25 μ inches) min.  
2. CP wire Immersion Sn on terminal : Thickness:Sn plating,100%,5 μm (200 μ inches) min.  
3. Coplanarity deviation: 0.10 mm (0.004 inches) max.

REV 1



**A-CORE**A-CORE JIANGMEN ELECTRONICS CO.,LTD  
江門安磁電子有限公司**TBI**TRANSFORMER BOBBIN  
INDUSTRIAL CO.,LTD.

ELECTRICAL CO. Tel : 86-750-3867791 Fax : 86-750-3867787

Tel : 86-769-88789999 Fax : 86-769-88789989

e-mail : sales@acore-ferrite.com

http:// tbi-tw.com e-mail : tb6688@ms46.hinet.net

## REVISIONS

REV	SYM	DRAFTER	CHECKER	DATE
△1		X.H.GU	G.F.YANG	10/24/16
△2				
△3				

## TOP

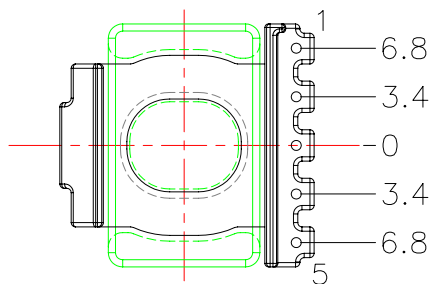
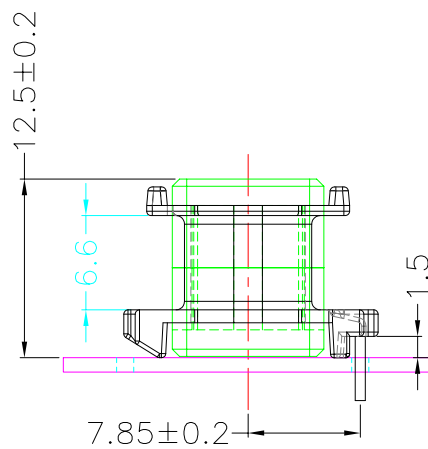
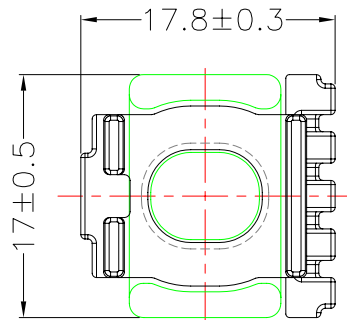

## BOTTOM

ITEM	PART NO.	MATERIAL	DWG NO.	Core Set Parameters
CORE	ATQ17/12.4A	JPP-44A		$A_e=40.2\text{mm}^2$ $L_e=33.2\text{mm}$ $C1=0.826\text{mm}^{-1}$ $V_e=1334.64\text{mm}^3$
CORE	ATQ17/12.4A	JPP-95		
BOBBIN	TBI-238-26011.11XX		ATQ17-12.4A-5P-TH-A-11	

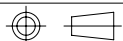

UNIT : m/m

SCALE 1 : 1

REV 1