



TRANSFORMER BOBBIN
INDUSTRIAL CO.,LTD.

Tel : 86-769-88789999 Fax : 86-769-88789989
http:// tbi-tw.com e-mail : tb6688@ms46.hinet.net

REVISIONS

REV	SYM	DRAFTER	CHECKER	DATE
△1		F.LU	G.F.YANG	12/14/12
△2				
△3				

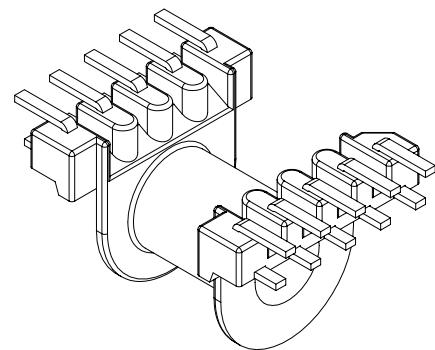
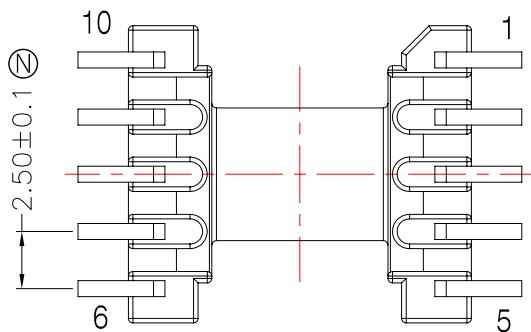
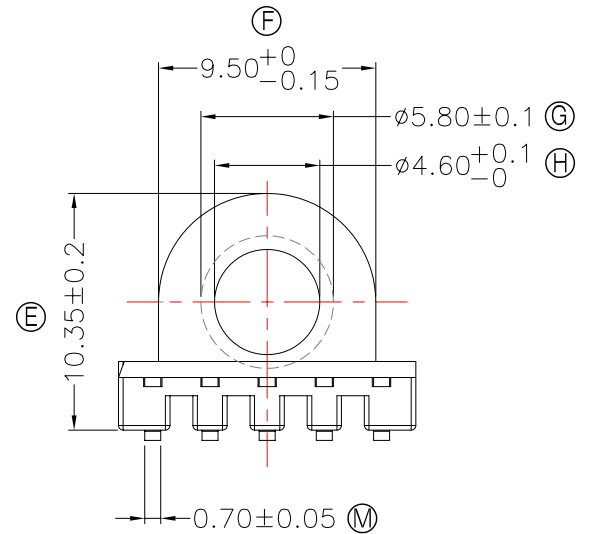
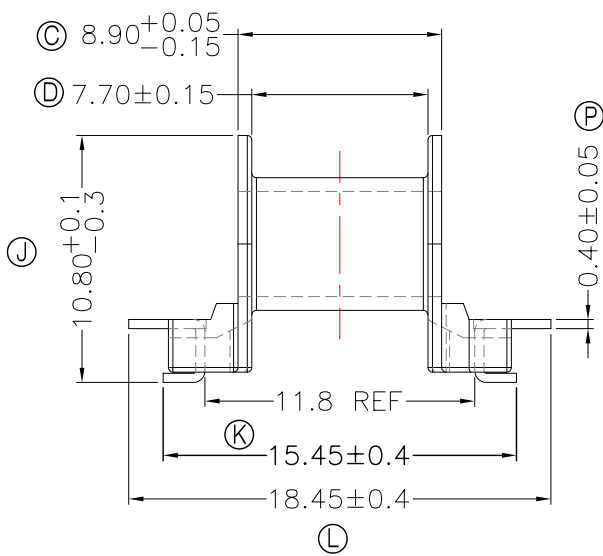
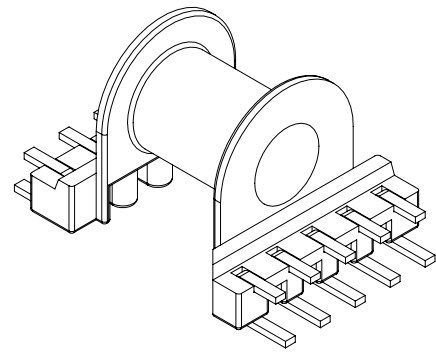
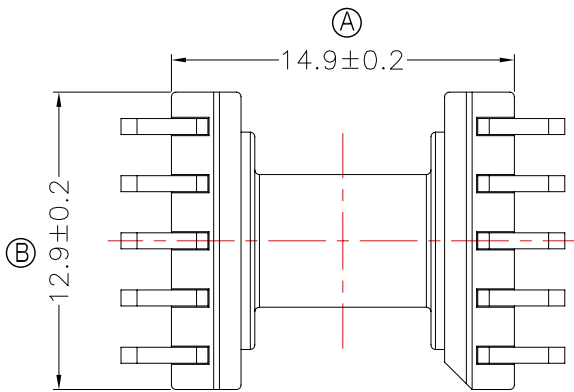

DWG NO. EP13-10P-J-2.5-E6-11

PART NO. MATERIAL (BOBBIN) MATERIAL (TERMINAL) TERMINAL (PLATING) PIN ALLOCATION NOTE

TBI-103-03561.1103

PM-9630

PB

Sn

ALL PIN

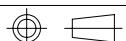

TOLERANCE: 0<L<=4:±0.1 4<L<=16:±0.2 16<L<=63:±0.3

UNIT : m / m

SCALE 1 : 1

Finish: 1. PB wire Immersion Sn on terminal : Thickness:Sn plating,100%,5 μm (200 μ inches) min,Base nickel 1-2.5 μm (40-100 μ inches) min.
2. CP wire Immersion Sn on terminal : Thickness:Sn plating,100%,5 μm (200 μ inches) min.
3. Coplanarity deviation: 0.10 mm (0.004 inches) max.

REV 1