



TRANSFORMER BOBBIN  
INDUSTRIAL CO.,LTD.

Tel : 86-769-88789999 Fax : 86-769-88789989  
http:// tbi-tw.com e-mail : tb6688@ms46.hinet.net

REVISIONS

| REV | SYM | DRAFTER  | CHECKER | DATE     |
|-----|-----|----------|---------|----------|
| 1   |     | G.F.YANG | W.H.HSU | 09/01/18 |
| 2   |     |          |         |          |
| 3   |     |          |         |          |

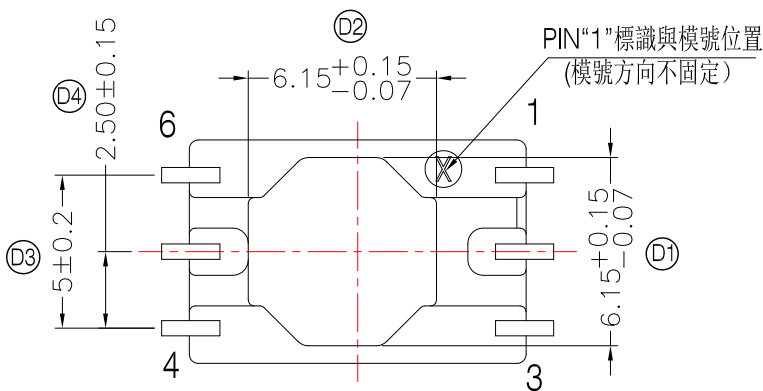
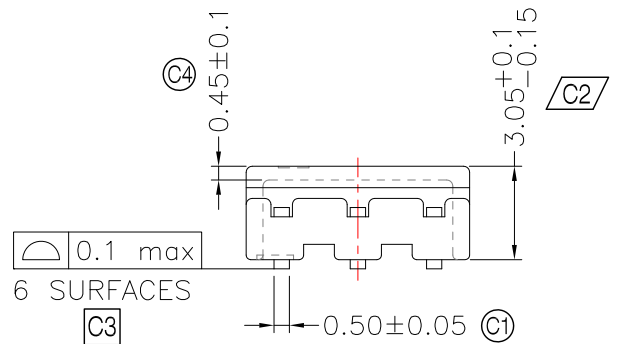
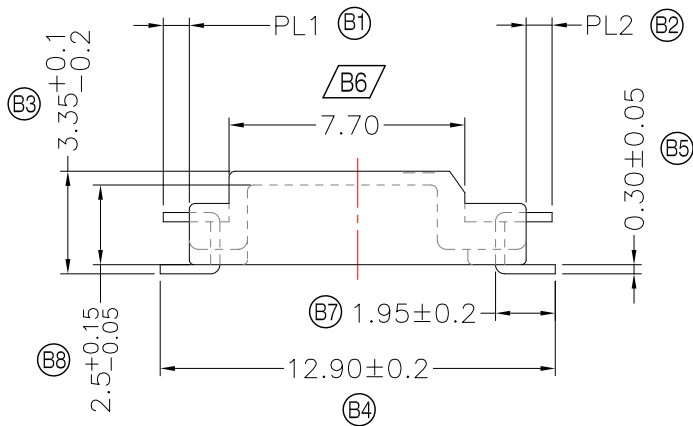
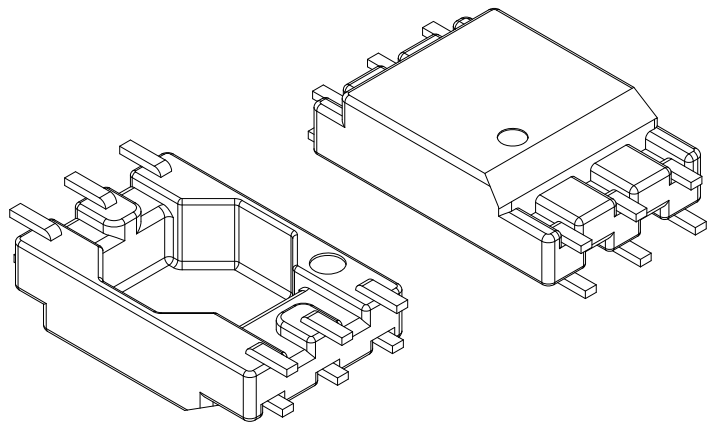
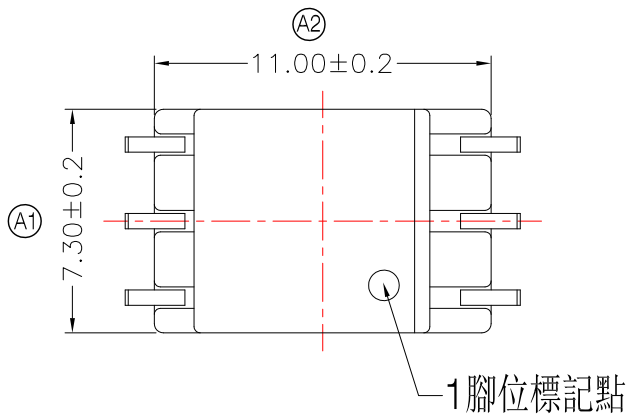

NOTE

1. PIN切面100%鍍錫,不可氧化;
2. PIN平面度要求0.1max;
3. 可焊性:400±10度,2~3S,Pin腳表面光亮;
4. PIN鍍鎳層要求0.5~4.0um; 鍍錫層要求3.0~15.0um;
5. 標示 (XX) 的尺寸CPK 1.33 Min; 標示 (XX) 的尺寸CPK 1.67 Min; 標識 (XY) 為次要參考尺寸;

DWG NO. H1107-6P-J-E-11

| PART NO.           | MATERIAL (BOBBIN) | MATERIAL (TERMINAL) | TERMINAL (PLATING) | PIN ALLOCATION                          |
|--------------------|-------------------|---------------------|--------------------|---|
| TBI-120-05051.1103 | PM-9630           | PB (C5191)          | Sn                 | ALL PIN PL1=0.75±0.15 PL2=0.75±0.15 S   |
| TBI-120-05051.1113 | PM-9630           | PB (C5191)          | Sn                 | ALL PIN PL1=0.85±0.15 PL2=0.85±0.15 H   |
| TBI-120-05051.1123 | PM-9630           | PB (C5191)          | Sn                 | CUT PIN#2,5 PL1=0.85±0.15 PL2=0.85±0.15 |

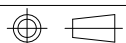

TOLERANCE:0<L<=4:±0.1 4<L<=16:±0.2 16<L<=63:±0.3

UNIT : m / m

SCALE 1 : 1

Finish: 1. PB wire Immersion Sn on terminal : Thickness:Sn plating,100%,5 μ m (200 μ inches) min,Base nickel 0.625 μ m (25 μ inches) min.  
2. CP wire Immersion Sn on terminal : Thickness:Sn plating,100%,5 μ m (200 μ inches) min.  
3. Coplanarity deviation: 0.10 mm (0.004 inches) max.

REV 1