

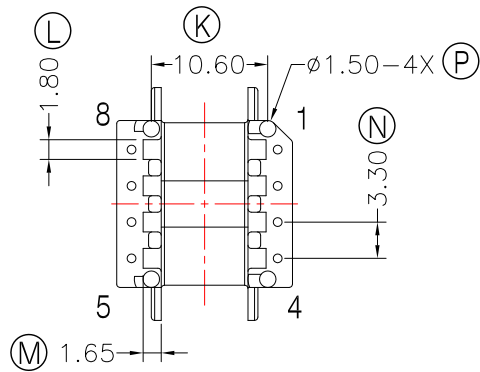

TRANSFORMER BOBBIN
INDUSTRIAL CO.,LTD.

Tel : 86-769-88789999 Fax : 86-769-88789989
http:// tbi-tw.com e-mail : tb6688@ms46.hinet.net

REVISIONS				
REV	SYM	DRAFTER	CHECKER	DATE
1		X.H.GU	G.F.YANG	03/21/22
2				
3				

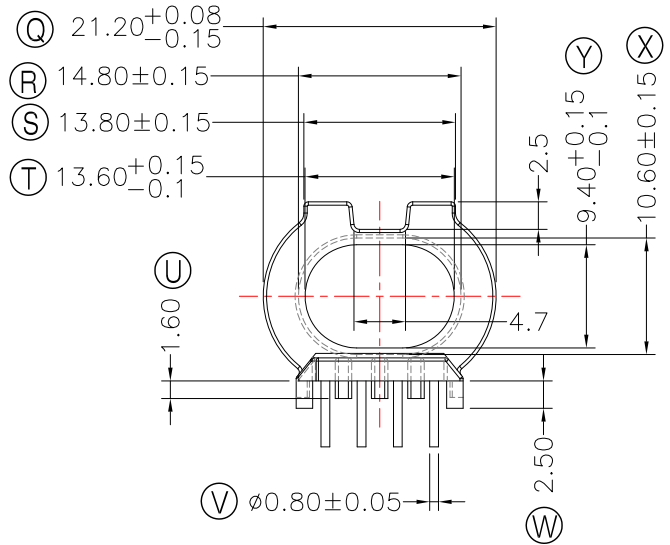
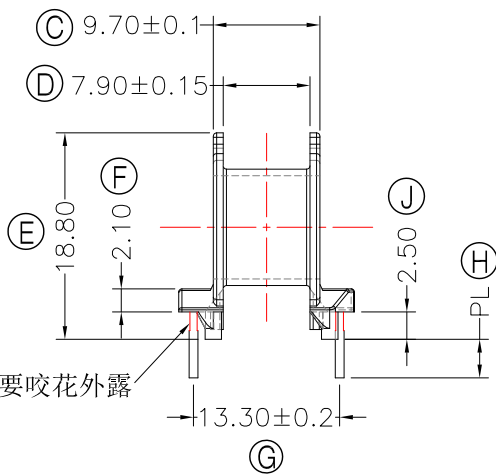
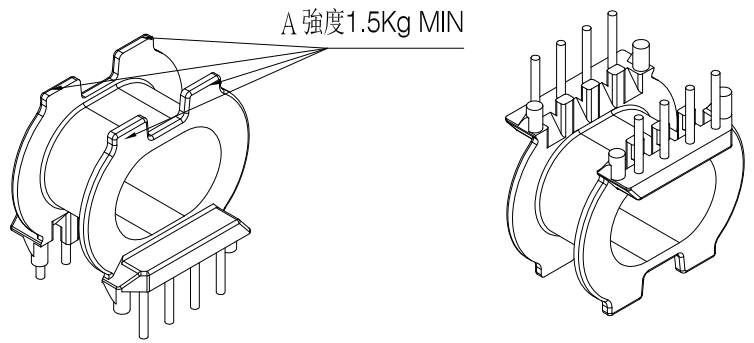
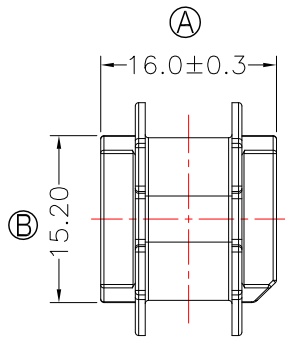

NOTE:

- 1.耐壓4.0Kv /1.5mA 60S;
- 2.焊錫溫度:450°±10° 3SEC.
- 3.PIN拉力須焊前1.0KgMIN;焊后1.5KgMIN.
- 4.任一點的強度為2.0kg MIN;其中葉片A處為1.5kg MIN;

DWG NO. ATQ25-16N-8P-TH-3.3-C9-11

PART NO.	MATERIAL (BOBBIN)	MATERIAL (TERMINAL)	TERMINAL (PLATING)	PIN ALLOCATION	NOTE
TBI-238-09391.1106	PM-9630	CP WIRE	Sn	ALL PIN PL=3.7±0.2	H
TBI-238-09391.1116	PM-9630	CP WIRE	Sn	CUT PIN#1,3,5,7,8 PL=3.7±0.2	
TBI-238-09391.1126	PM-9630	CP WIRE	Sn	CUT PIN#2,3,5,6,8 PL=3.7±0.2	
TBI-238-09391.1136	PM-9630	CP WIRE	Sn	CUT PIN#2,3,5,6,8 PL=3.2±0.2	

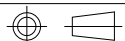

TOLERANCE: 0<L<=4:±0.1 4<L<=16:±0.2 16<L<=63:±0.3

UNIT : m / m

SCALE 1 : 1

Finish: 1. PB wire Immersion Sn on terminal : Thickness:Sn plating,100,5 μ m (200 μ inches) min,Base nickel 0.625 μ m (25 μ inches) min.
2. CP wire Immersion Sn on terminal : Thickness:Sn plating,100,5 μ m (200 μ inches) min.
3. Coplanarity deviation: 0.10 mm (0.004 inches) max.

REV 1