

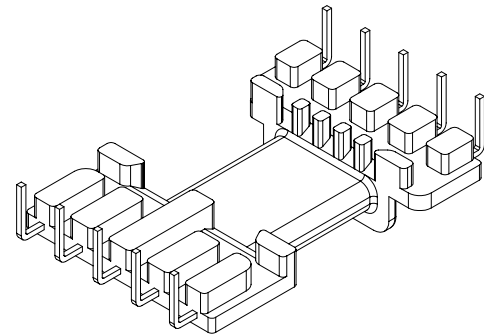

TRANSFORMER BOBBIN INDUSTRIAL CO.,LTD.

Tel : 86-769-88789999 Fax : 86-769-88789989
 http://tbi-tw.com e-mail : tb6688@ms46.hinet.net

REVISIONS				
REV	SYM	DRAFTER	CHECKER	DATE
①		X.H.GU	G.F.YANG	10/21/09
②				
③				

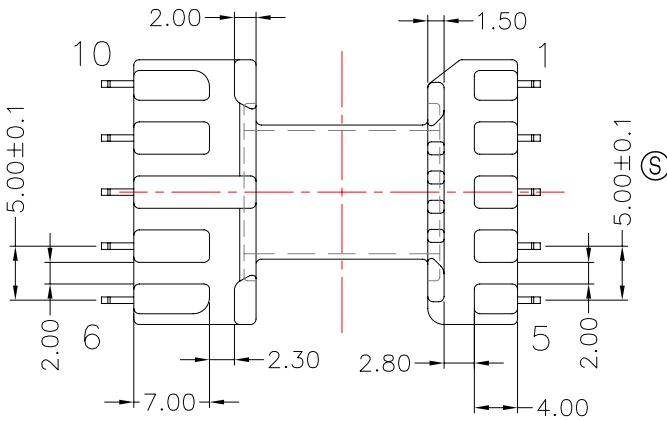
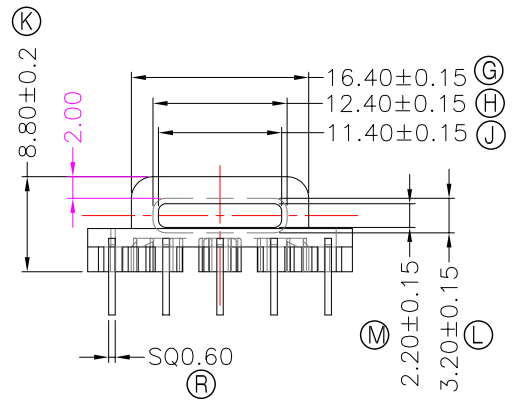
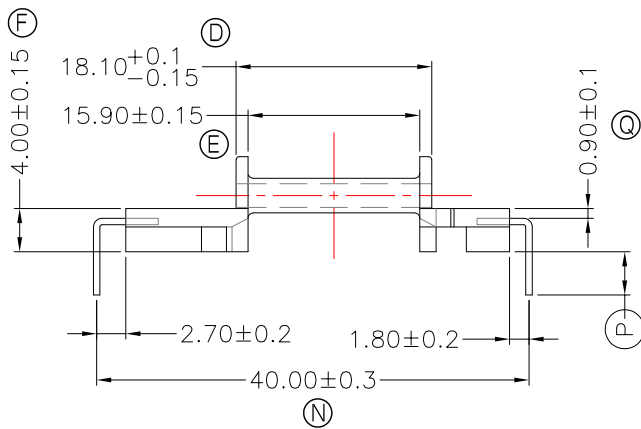
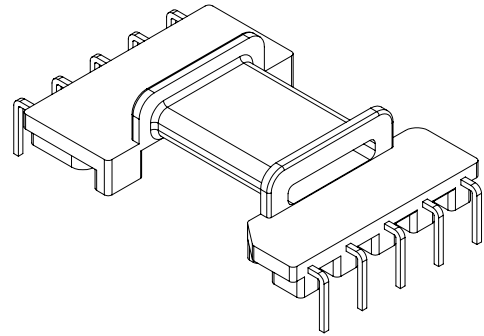
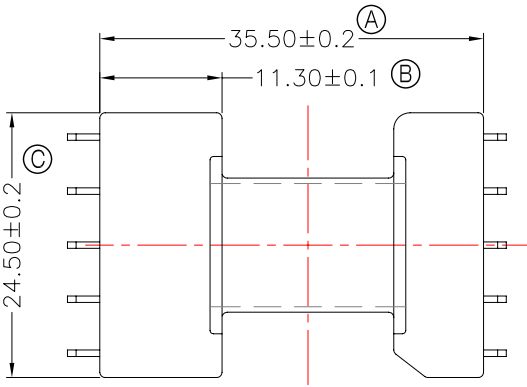

NOTE:
 1. PIN排距焊前焊後的公差均為:±0.3mm;
 2. WINDING SPACE: 15.9*2.0mm=31.8mm²

DWG NO.	EFD22.5-24-10P-THT-0B-11				
PART NO.	MATERIAL (BOBBIN)	MATERIAL (TERMINAL)	TERMINAL (PLATING)	PIN ALLOCATION	NOTE
TBI-207-07021.1106	PM-9630	CP WIRE	Sn	ALL PIN (P)=4.0±0.2	S
TBI-207-07021.1116	PM-9630	CP WIRE	Sn	CUT PIN#8 (P)=4.0±0.2	H
TBI-207-07021.1126	PM-9630	CP WIRE	Sn	CUT PIN#8 (P)=3.5±0.2	
TBI-207-07021.1136	PM-9630	CP WIRE	Sn	ALL PIN (P)=3.8±0.3	
TBI-207-07021.1146	PM-9630	CP WIRE	Sn	CUT PIN#8 (P)=5.0±0.2	
TBI-207-07021.1156	PM-9630	CP WIRE	Sn	ALL PIN (P)=3.5±0.2	
TBI-207-07021.1166	PM-9630	CP WIRE	Sn	CUT PIN#8 (P)=3.8±0.3	
TBI-207-07021.1176	PM-9630	CP WIRE	Sn	ALL PIN (P)=3.1±0.2	
TBI-207-07021.1186	PM-9630	CP WIRE	Sn	CUT PIN#6 (P)=3.2±0.2	

TOLERANCE: 0<L<=4:±0.1 4<L<=16:±0.2 16<L<=63:±0.3 UNIT : m/m SCALE 1:1

Finish: 1. PB wire Immersion Sn on terminal : Thickness:Sn plating,100,5μm (200μinches) min,Base nickel 0.625μm (25μinches) min.
 2. CP wire Immersion Sn on terminal : Thickness:Sn plating,100,5μm (200μinches) min.
 3. Coplanarity deviation: 0.10 mm (0.004 inches)max.

REV 1

A-CORE

A-CORE JIANGMEN ELECTRONICS CO.,LTD
 江门安磁电子有限公司

TBI

TRANSFORMER BOBBIN
 INDUSTRIAL CO.,LTD.

ELECTRICAL CO. Tel : 86-750-3867791 Fax : 86-750-3867787

Tel : 86-769-88789999 Fax : 86-769-88789989

e-mail : sales@acore-ferrite.com

http:// tbi-tw.com e-mail : tb6688@ms46.hinet.net

REVISIONS

REV	SYM	DRAFTER	CHECKER	DATE
△1		X.H.GU	G.F.YANG	10/21/09
△2				
△3				

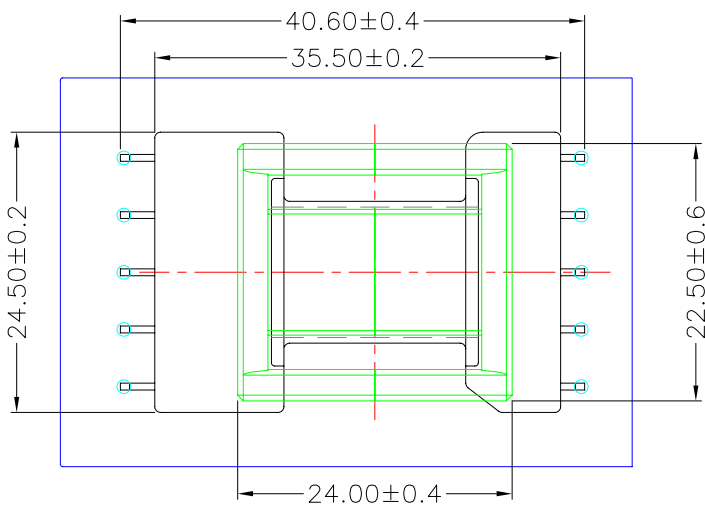

TOP

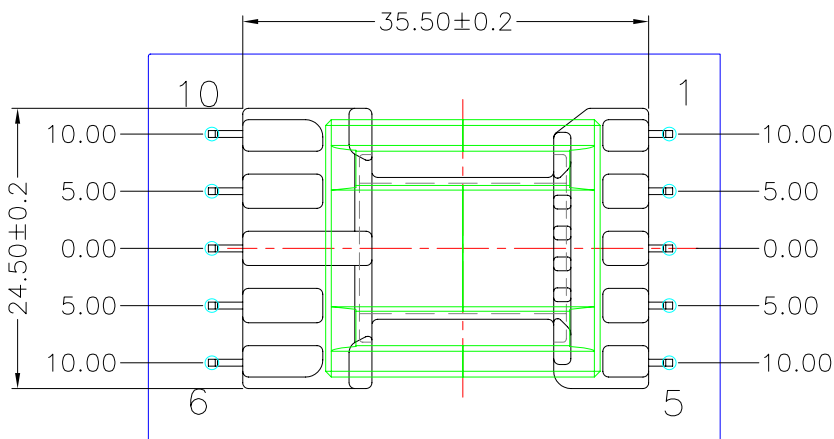
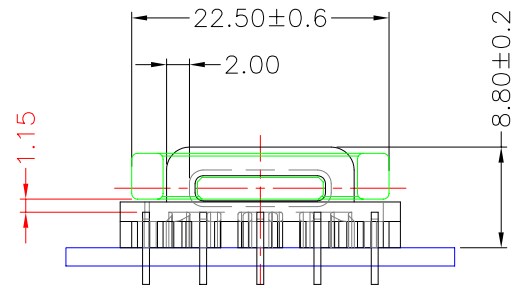
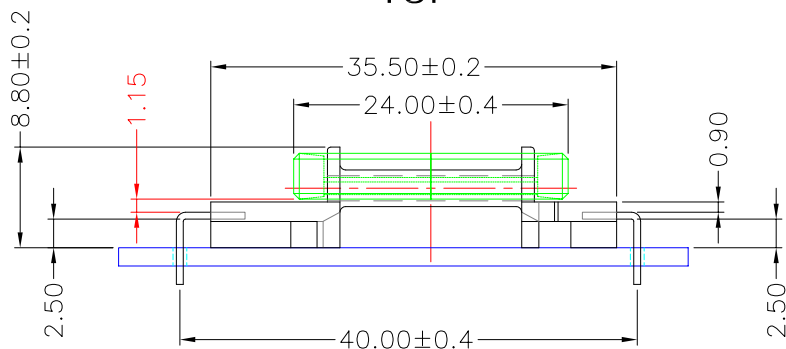
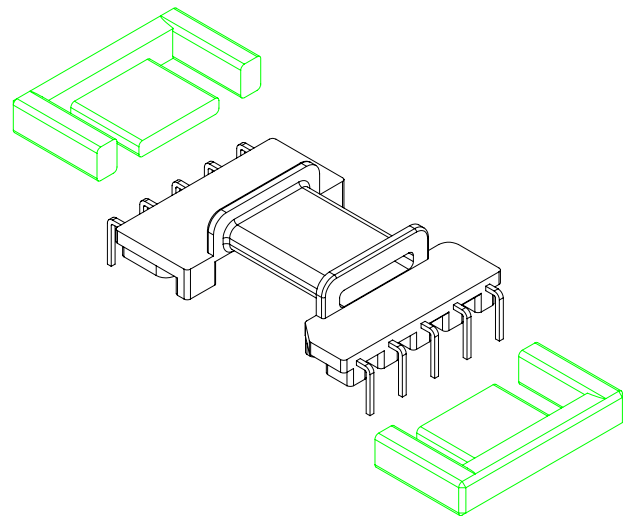

BOTTOM

Core Set Parameters

$C1=2.54\text{mm}^{-1}$
 $Le=54\text{mm}$
 $Ae=21.3\text{mm}^2$
 $Ve=1150.2\text{mm}^3$

ITEM	PART NO.	MATERIAL	DWG NO.	NOTE
CORE	EFD22.5-24	JPP-44A		
CORE	EFD22.5-24	JPP-95		
BOBBIN	TBI-207-07021.11XX		EFD22.5-24-10P-THT-0B-11	

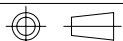

UNIT : m / m

SCALE 1 : 1

REV 1