

A-CORE

A-CORE JIANGMEN ELECTRONICS CO.,LTD
 江门安磁电子有限公司

ELECTRICAL CO. Tel : 86-750-3867791 Fax : 86-750-3867787

e-mail : sales@acore-ferrite.com

TBIE

TRANSFORMER BOBBIN
 INDUSTRIAL CO.,LTD.

Tel : 86-769-88789999 Fax : 86-769-88789989

http:// tbi-tw.com e-mail : tb6688@ms46.hinet.net

REVISIONS

REV	SYM	DRAFTER	CHECKER	DATE
1		X.H.GU	G.F.YANG	12/15/11
2		X.H.GU	G.F.YANG	08/21/12
3				

TOP

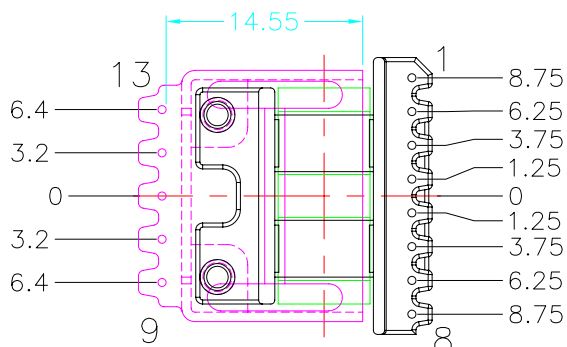
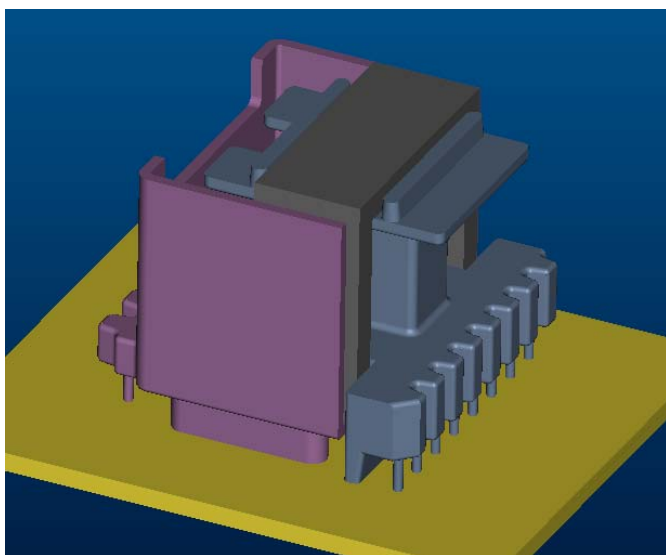
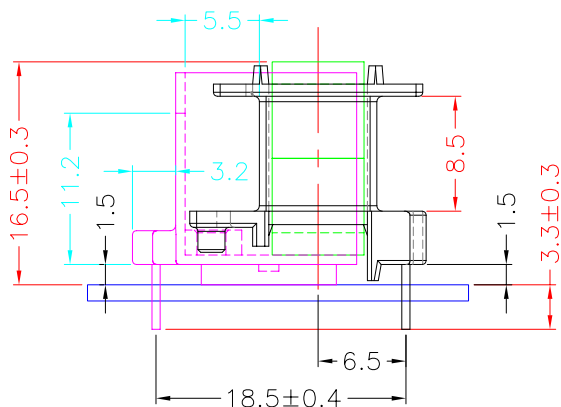
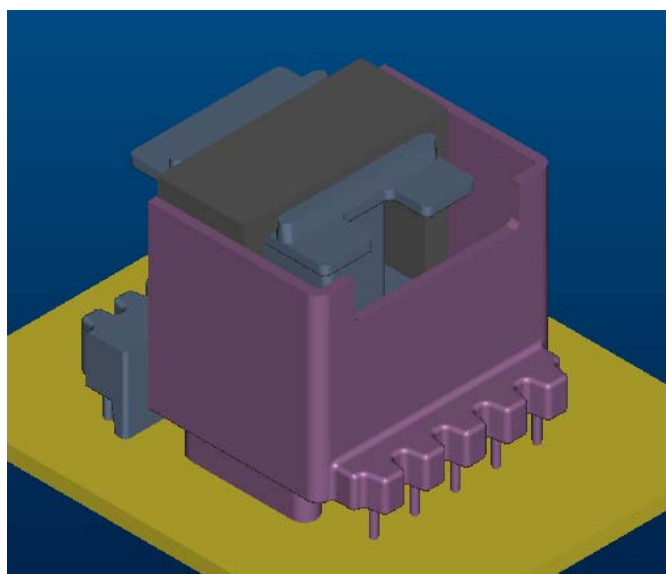
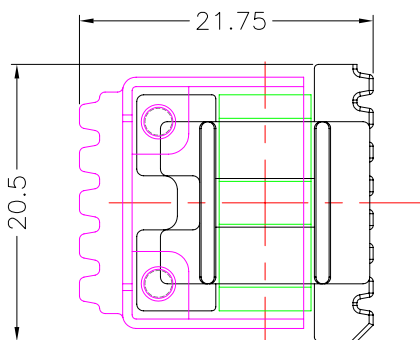

BOTTOM

ITEM	PART NO.	MATERIAL	DWG NO.	Core Set Parameters
CORE	EE16/14A	JPP-44A		$A_e=21.9\text{mm}^2$ $L_e=36.7\text{mm}$ $C_1=1.68\text{mm}^{-1}$ $V_e=804\text{mm}^3$
CORE	EE16/14A	JPP-95		
BOBBIN	TBI-201-09121.12XX		EE16-14A-8P-TH-A2-12	
CASE	TBI-201-09131.11XX		EE16-14A-5P-CASE-A3-11	

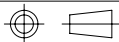

UNIT : m/m

SCALE 1:1

REV 2