



**TRANSFORMER BOBBIN INDUSTRIAL CO.,LTD.**

Tel : 86-769-88789999 Fax : 86-769-88789989  
 http:// tbi-tw.com e-mail : tb6688@ms46.hinet.net

**REVISIONS**

REV	SYM	DRAFTER	CHECKER	DATE
①		G.F.YANG	W.H.HSU	12/19/19
②				
③				

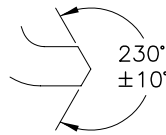
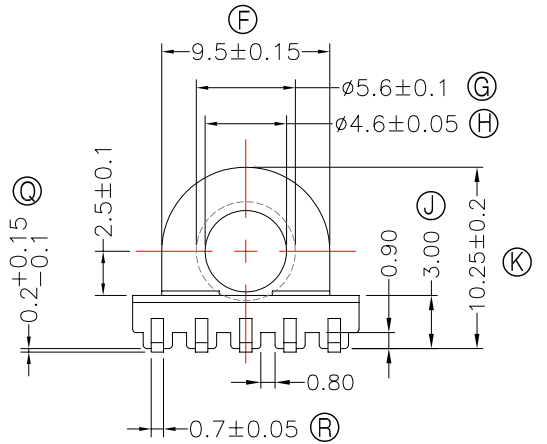
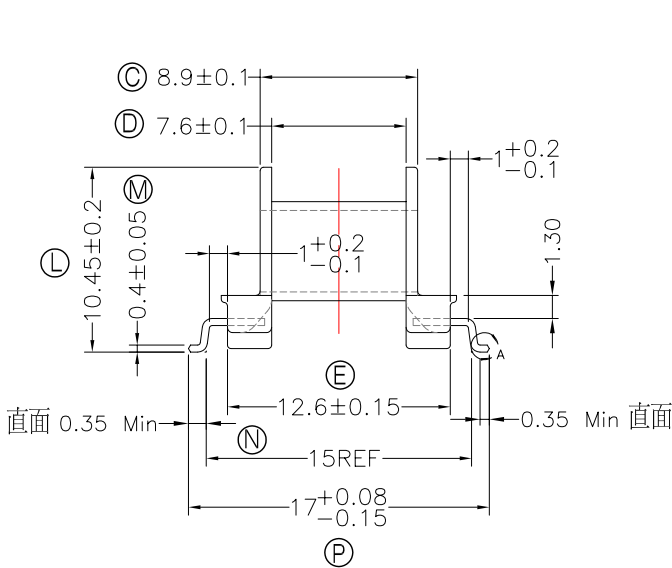
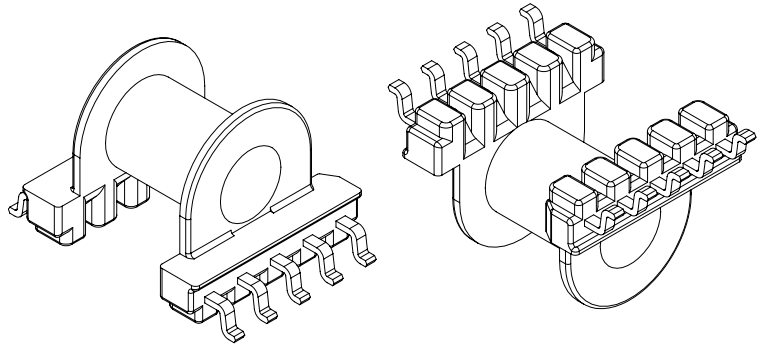
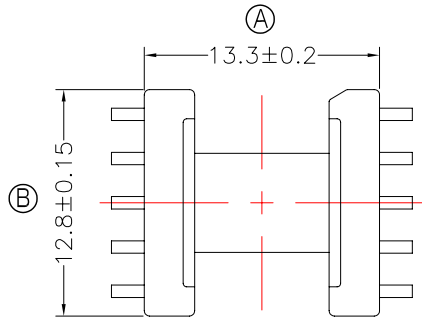

DETAIL:A  
PATENTED

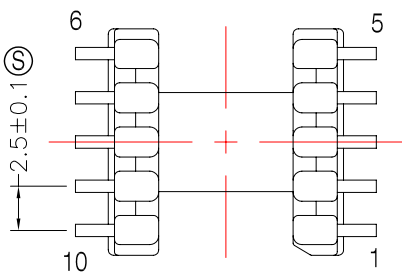

**NOTE:**

1.焊前拉力要求: 1.0 Kg Min.

DWG NO. EP13-10P-GW-2.5-9G-11

PART NO. MATERIAL (BOBBIN) MATERIAL (TERMINAL) TERMINAL (PLATING) PIN ALLOCATION NOTE

TBI-103-03971.1103	PM-9630	PB	Sn	ALL PIN		S
						H

TOLERANCE: 0<L<=4:±0.1 4<L<=16:±0.2 16<L<=63:±0.3 UNIT : m / m SCALE 1 : 1

Finish: 1. PB wire Immersion Sn on terminal : Thickness:Sn plating,100%,5 μm (200 μ inches) min,Base nickel 0.625 μm (25 μ inches) min.  
 2. CP wire Immersion Sn on terminal : Thickness:Sn plating,100%,5 μm (200 μ inches) min.  
 3. Coplanarity deviation: 0.10 mm (0.004 inches) max.

REV 1