



TRANSFORMER BOBBIN
INDUSTRIAL CO.,LTD.

Tel : 86-769-88789999 Fax : 86-769-88789989
http:// tbi-tw.com e-mail : tb6688@ms46.hinet.net

REVISIONS

REV	SYM	DRAFTER	CHECKER	DATE
①		X.X.YUAN	G.F.YANG	04/02/16
②		X.H.GU	G.F.YANG	05/16/16
③				

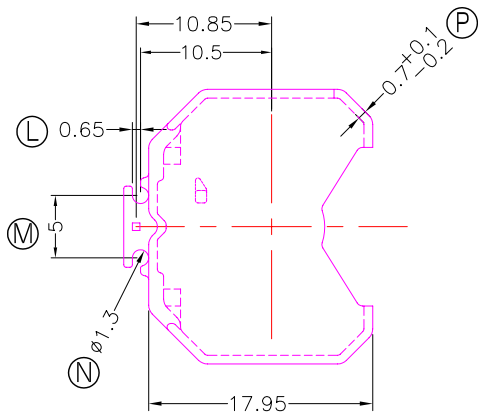
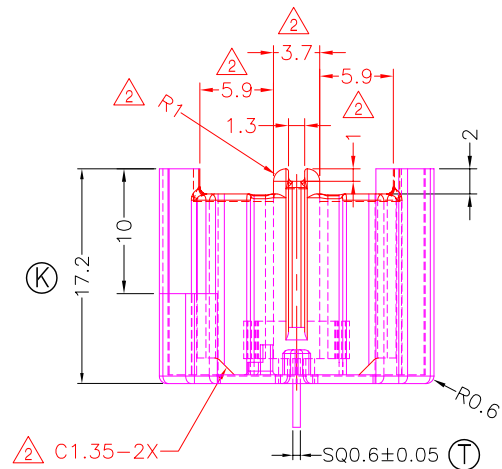
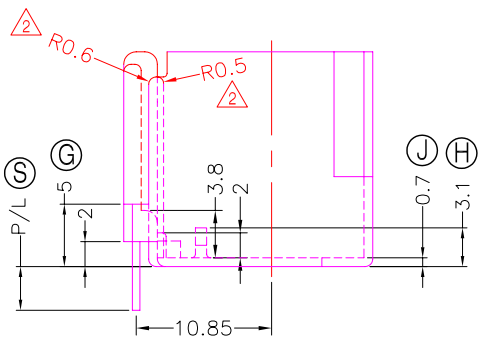
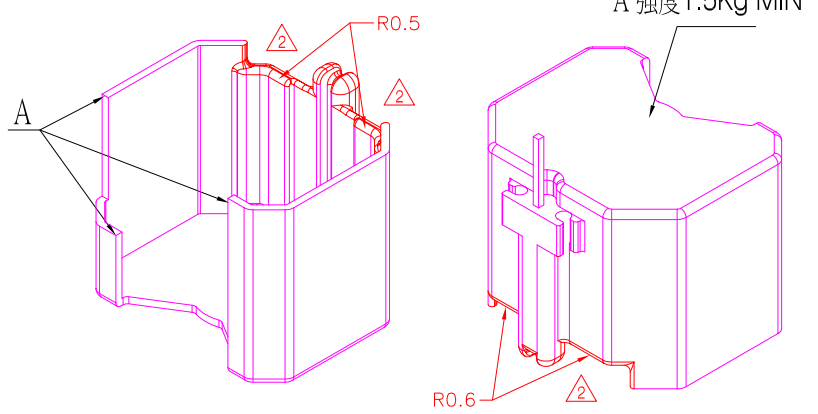
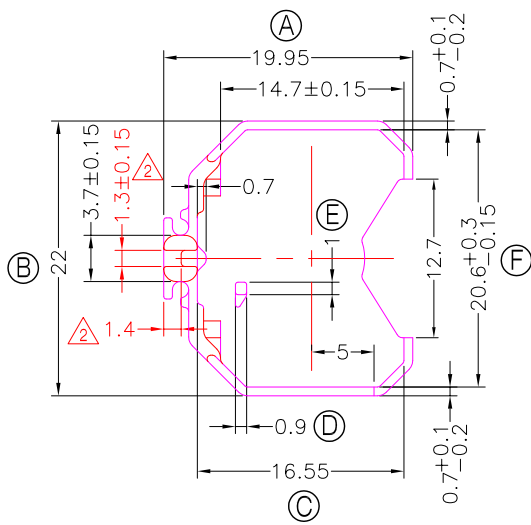

NOTE:

- 1.耐壓4.0Kv /1.5mA 60S;
- 2.焊錫溫度:450°±10° 3SEC;
- 3.任意一點強度須1.8kg Min, 其中A處強度為1.5Kg Min;
- 4.焊錫前拉力:1.0KG MIN;焊錫後拉力:1.5KG MIN
與TBI-247-01061.11XX(LQ20-16.8-8P-TH-F-11)配套使用;

DWG NO. LQ20-16.8-1P-CASE-H-11

PART NO.	MATERIAL (BOBBIN)	MATERIAL (TERMINAL)	TERMINAL (PLATING)	PIN ALLOCATION	NOTE
TBI-247-01081.1106	PM-9630	CP WIRE	Sn	ALL PIN P/L=3.5±0.2	S
TBI-247-01081.1116	PM-9630	CP WIRE	Sn	NO PIN	H
TBI-247-01081.1126	PM-9630	CP WIRE	Sn	ALL PIN P/L=5.0±0.2	

TOLERANCE: 0<L<=4:±0.1 4<L<=16:±0.2 16<L<=63:±0.3

UNIT : m / m

SCALE 1 : 1

Finish: 1. PB wire Immersion Sn on terminal : Thickness:Sn plating,100%,5 μm (200 μ inches) min,Base nickel 0.625 μm (25 μ inches) min.
2. CP wire Immersion Sn on terminal : Thickness:Sn plating,100%,5 μm (200 μ inches) min.
3. Coplanarity deviation: 0.10 mm (0.004 inches) max.

REV 2