



TRANSFORMER BOBBIN  
INDUSTRIAL CO.,LTD.

Tel : 86-769-88789999 Fax : 86-769-88789989  
http:// tbi-tw.com e-mail : tb6688@ms46.hinet.net

REVISIONS

REV	SYM	DRAFTER	CHECKER	DATE
①		T.S.LII	W.H.HSU	09/02/06
②				
③				

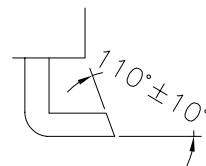
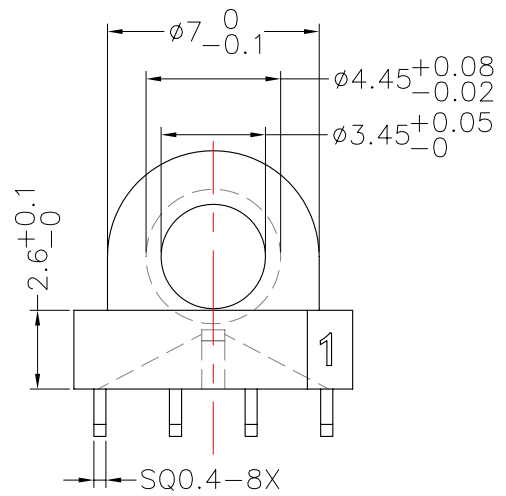
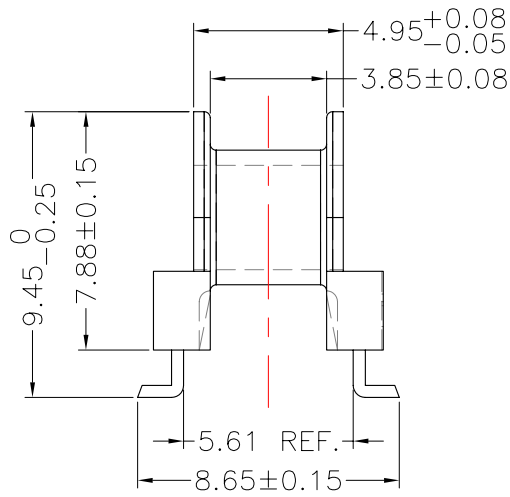
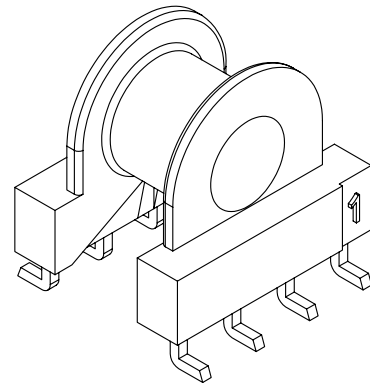
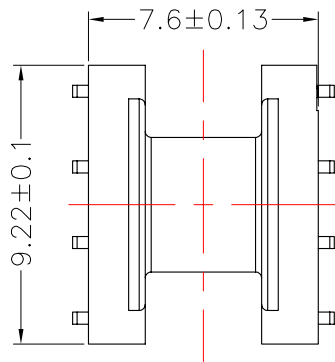

DETAIL : A  
(PATENTED)

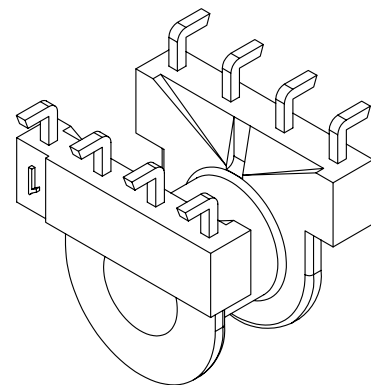
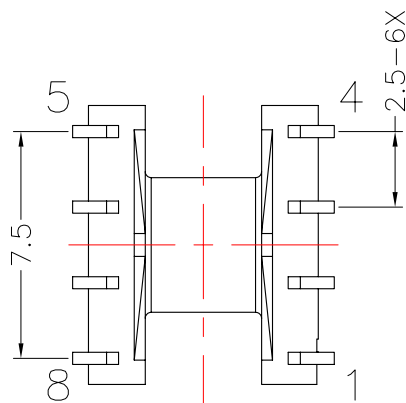

DWG NO. EP7-8P-L-2.5V-C0-1

PART NO.	MATERIAL (BOBBIN)	MATERIAL (TERMINAL)	TERMINAL (PLATING)	PIN ALLOCATION	NOTE
TBI-103-08301.103	PM-9630	PB	Sn	ALL PIN	042-2297.003

	TOLERANCE: .X±0.15 .XX±0.10 .XXX±0.05	UNIT : m / m	SCALE 4 : 1
--	---------------------------------------	--------------	-------------

Finish: 1. PB wire Immersion Sn on terminal : Thickness:Sn plating,100,5 μ m (200 μ inches) min,Base nickel 0.625 μ m (25 μ inches) min.  
2. CP wire Immersion Sn on terminal : Thickness:Sn plating,100,5 μ m (200 μ inches) min.  
3. Coplanarity deviation: 0.10 mm (0.004 inches) max.

REV 1