

A-CORE

A-CORE JIANGMEN ELECTRONICS CO.,LTD
 江门安磁电子有限公司

TBI

TRANSFORMER BOBBIN
 INDUSTRIAL CO.,LTD.

ELECTRICAL CO. Tel : 86-750-3867791 Fax : 86-750-3867787

Tel : 86-769-88789999 Fax : 86-769-88789989

e-mail : sales@acore-ferrite.com

http:// tbi-tw.com e-mail : tb6688@ms46.hinet.net

REVISIONS

REV	SYM	DRAFTER	CHECKER	DATE
①		M.WANG	G.F.YANG	08/09/16
②		X.H.GU	G.F.YANG	09/29/16
③				

TOP

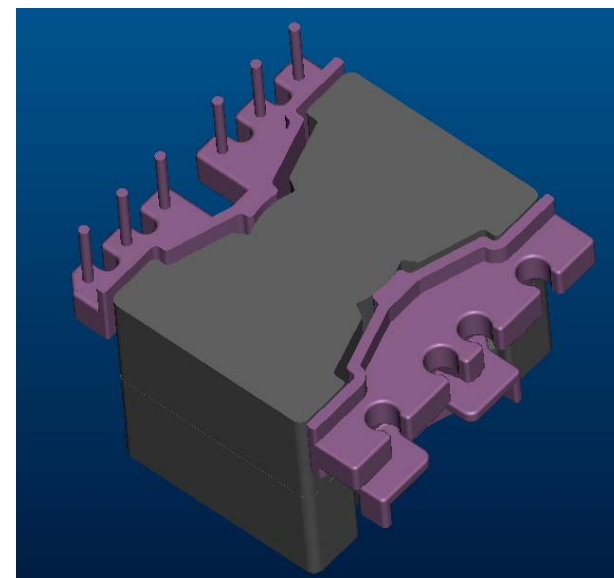
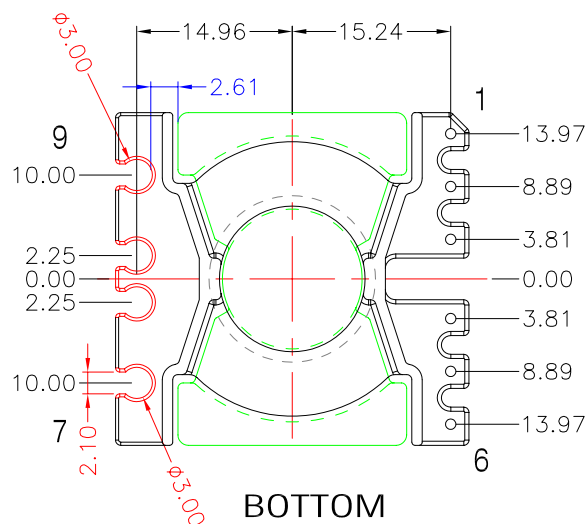
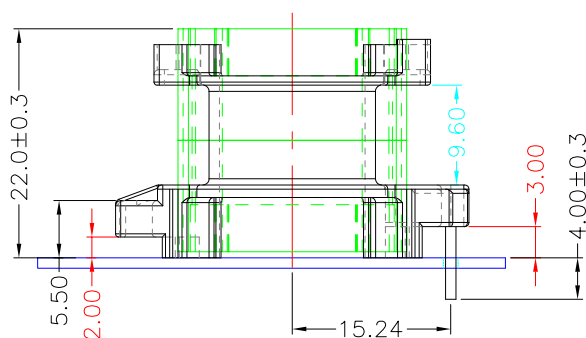
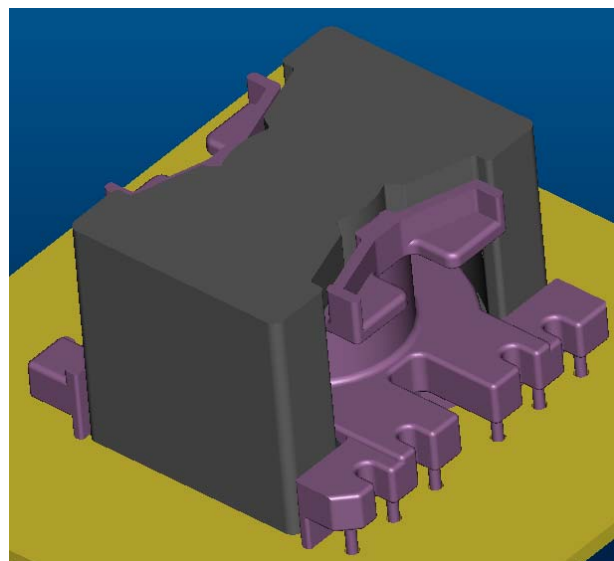
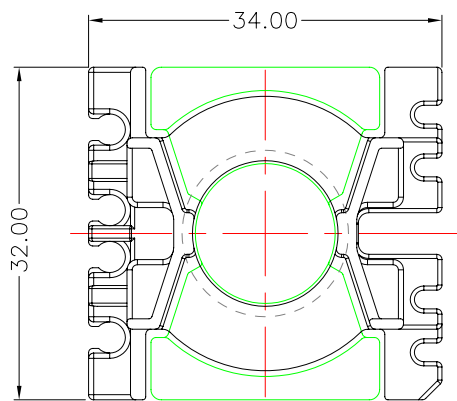

BOTTOM

ITEM	PART NO.	MATERIAL	DWG NO.	Core Set Parameters
CORE	PQ32/21	JPP-44A		$A_e=153.0\text{mm}^2$ $L_e=50.6\text{mm}$ $C_1=0.331\text{mm}^{-1}$ $V_e=7741.8\text{mm}^3$
CORE	PQ32/21	JPP-95		
BOBBIN	TBI-216-13191.17XX		PQ3221-6P-TH-A9-17	

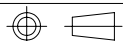

UNIT : m/m

SCALE 1:1

REV

2