

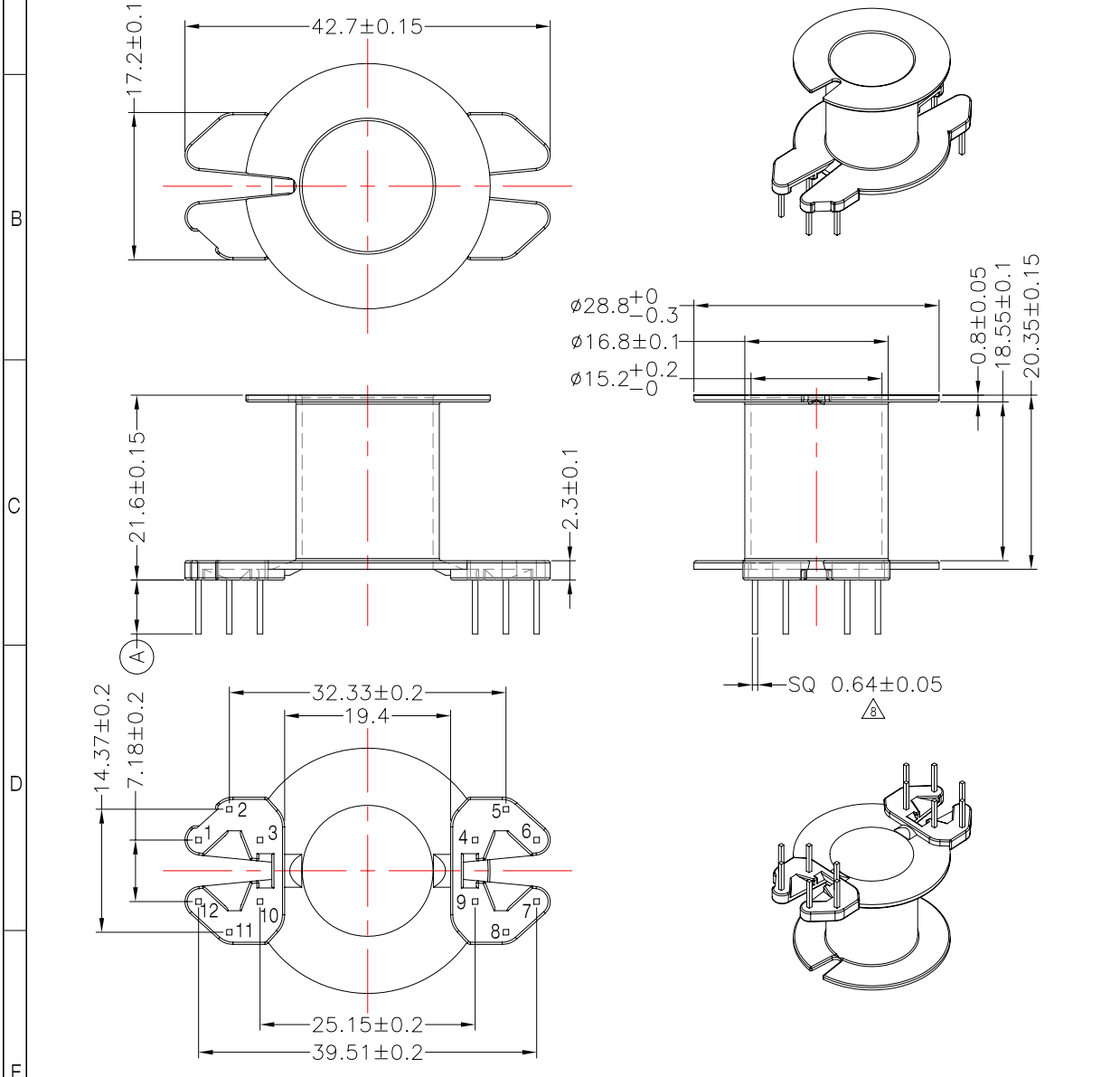

TRANSFORMER BOBBIN INDUSTRIAL CO.,LTD.

Tel : 86-769-88789999 Fax : 86-769-88789989
http:// tbi-tw.com e-mail : tb6688@ms46.hinet.net

REVISIONS				
REV	SYM	DRAFTER	CHECKER	DATE
△		T.S.LII	W.H.HSU	02/17/04
△		T.S.LII	W.H.HSU	07/24/06
△		T.S.LII	W.H.HSU	01/27/07



DWG NO.	RM14-12P-TH-A-1				
PART NO.	MATERIAL (BOBBIN)	MATERIAL (TERMINAL)	TERMINAL (PLATING)	PIN ALLOCATION	NOTE
TBI-208-08011.106	PM-9630	CP WIRE	Sn	ALL PIN ①=6.3±0.3	
△ TBI-208-08011.116	PM-9630	CP WIRE	Sn	CUT PIN #5,8 ①=6.3±0.3	H
△ TBI-208-08011.126	PM-9630	CP WIRE	Sn	CUT PIN #1,2,11,12 ①=6.3±0.3	
△ TBI-208-08011.136	PM-9630	CP WIRE	Sn	ALL PIN ①=6.9±0.2	
△ TBI-208-08011.146	PM-9630	CP WIRE	Sn	ALL PIN ①=9.5±0.2	
△ TBI-208-08011.156	PM-9630	CP WIRE	Sn	CUT PIN #5,8 ①=9.5±0.2	F
△ TBI-208-08011.166	PM-9630	CP WIRE	Sn	ALL PIN ①=8.0±0.3	
TBI-208-08011.176	PM-9630	CP WIRE	Sn	CUT PIN #1,2,11,12 ①=8.5±0.3	用8.0刀模做到上限8.2
TBI-208-08011.186	PM-9630	CP WIRE	Sn	CUT PIN #3,6,7,10 ①=9.5±0.2	
TBI-208-08011.196	PM-9630	CP WIRE	Sn	CUT PIN #7,8,9,10,11,12 ①=9.5±0.2	
TBI-208-08011.1A6	PM-9630	CP WIRE	Sn	CUT PIN #1,2,11,12 ①=7.3±0.2	
TBI-208-08011.1B6	PM-9630	CP WIRE	Sn	NO PIN 產品要求無粉末灰塵	
TBI-208-08011.1C6	PM-9630	CP WIRE	Sn	ALL PIN ①=8.5±0.3	用8.0刀模做到上限8.2
TBI-208-08011.1D6	PM-9630	CP WIRE	Sn	CUT PIN#8 ①=6.3±0.3	
TBI-208-08011.1E6	PM-9630	CP WIRE	Sn	CUT PIN#1,3,4,6,7,9,10,12 ①=8.5±0.3	
TBI-208-08011.1F6	PM-9630	CP WIRE	Sn	CUT PIN #7,8,9,10,11,12 ①=6.5±0.2	
TOLERANCE: .X±0.15 .XX±0.10 .XXX±0.05				UNIT : m / m	SCALE 1.5 : 1
Finish: 1. PB wire Immersion Sn on terminal : Thickness:Sn plating,100,5 μm (200 μ inches) min,Base nickel 0.625 μm (25 μ inches) min. 2. CP wire Immersion Sn on terminal : Thickness:Sn plating,100,5 μm (200 μ inches) min. 3. Coplanarity deviation: 0.10 mm (0.004 inches) jmax.					REV 8