

A-COREA-CORE JIANGMEN ELECTRONICS CO.,LTD
江门安磁电子有限公司**TBI**TRANSFORMER BOBBIN
INDUSTRIAL CO.,LTD.

ELECTRICAL CO. Tel : 86-750-3867791 Fax : 86-750-3867787

Tel : 86-769-88789999 Fax : 86-769-88789989

e-mail : sales@acore-ferrite.com

http:// tbi-tw.com e-mail : tb6688@ms46.hinet.net

REVISIONS

REV	SYM	DRAFTER	CHECKER	DATE
△3		X.H.GU	G.F.YANG	03/27/15
△4		X.H.GU	G.F.YANG	04/17/15
△5		X.H.GU	G.F.YANG	04/22/15

TOP

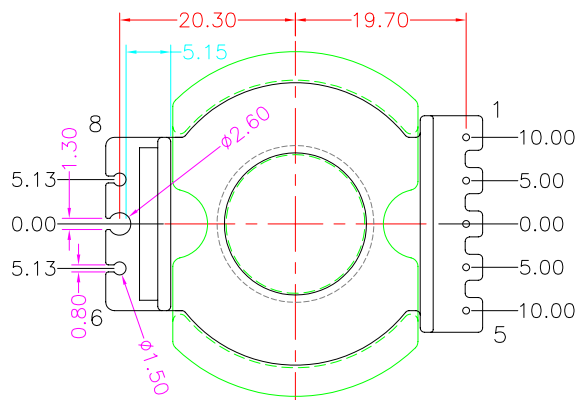
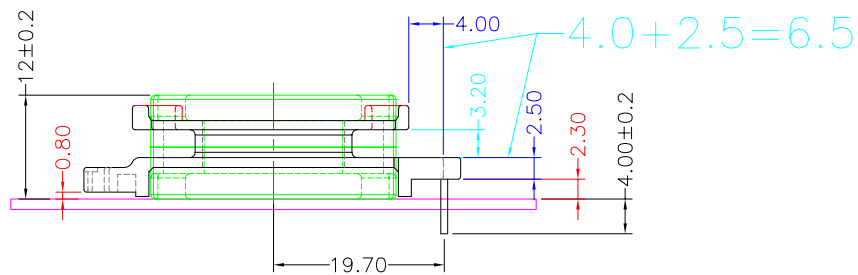
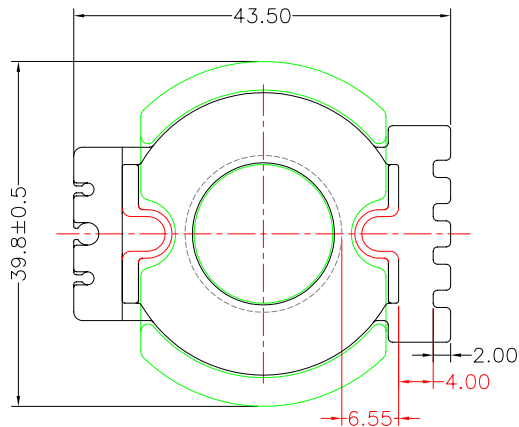

BOTTOM

ITEM	PART NO.	MATERIAL	DWG NO.	Core Set Parameters
CORE	CC40/12H	JPP-44A		$A_e=184\text{mm}^2$ $L_e=40.4\text{mm}$ $C_1=0.220\text{mm}^{-1}$ $V_e=7433.6\text{mm}^3$
CORE	CC40/12H	JPP-95		
BOBBIN	TBI-239-01461.12XX		CC40-12H-5P-TH-D6-12	

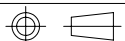

UNIT : m / m

SCALE 1 : 1

REV

5