



TRANSFORMER BOBBIN  
INDUSTRIAL CO.,LTD.

Tel : 86-769-88789999 Fax : 86-769-88789989  
http:// tbi-tw.com e-mail : tb6688@ms46.hinet.net

REVISIONS

REV	SYM	DRAFTER	CHECKER	DATE
1		X.H.GU	G.F.YANG	11/09/20
2				
3				

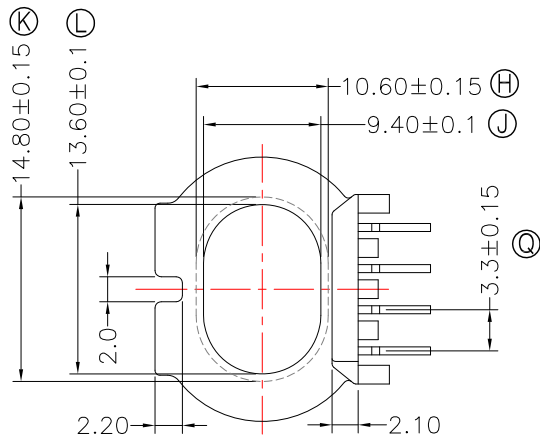
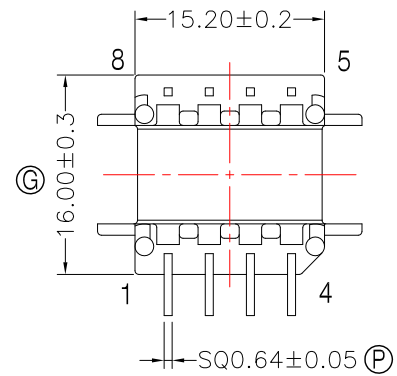
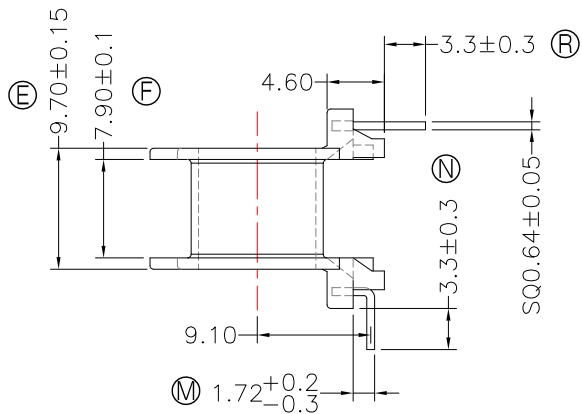
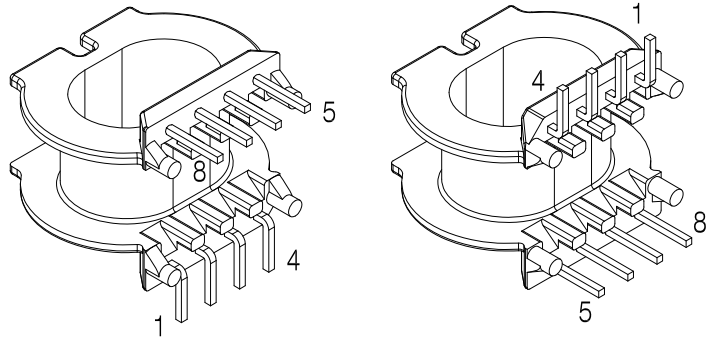
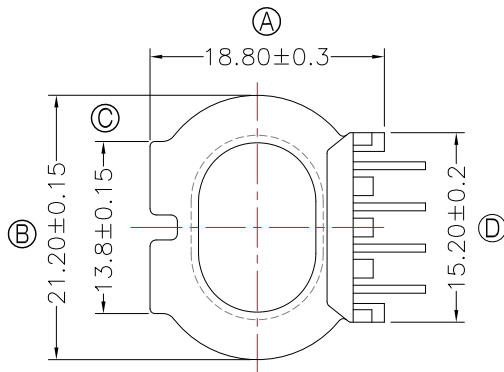

NOTE:

- 1.任一點的強度為1.5kg MIN.
- 2.耐壓4.0Kv /1.5mA 60S;
- 3.焊錫溫度:450°±10° 3SEC
- 4.PIN拉力須焊前1.0KgMIN;焊后1.5KgMIN.

DWG NO. ATQ25-16-8P-TL-3.3-C8-17

PART NO.	MATERIAL (BOBBIN)	MATERIAL (TERMINAL)	TERMINAL (PLATING)	PIN ALLOCATION	NOTE
TBI-238-09381.1706	PM-9823	CP WIRE	Sn	ALL PIN	H
TBI-238-09381.1716	PM-9823	CP WIRE	Sn	CUT PIN#5,7,8	
TBI-238-09381.1726	PM-9823	CP WIRE	Sn	CUT PIN#5,6,7,8	
TBI-238-09381.1736	PM-9823	CP WIRE	Sn	CUT PIN#6,7,8	

TOLERANCE: 0<L<=4:±0.1 4<L<=16:±0.2 16<L<=63:±0.3 UNIT : m/m SCALE 1:1

Finish: 1. PB wire Immersion Sn on terminal : Thickness:Sn plating,100%,5 μm (200 μ inches) min,Base nickel 0.625 μm (25 μ inches) min.  
2. CP wire Immersion Sn on terminal : Thickness:Sn plating,100%,5 μm (200 μ inches) min.  
3. Coplanarity deviation: 0.10 mm (0.004 inches) max.

REV 1