





**A-CORE**

A-CORE JIANGMEN ELECTRONICS CO.,LTD  
江門安磁電子有限公司

**TBI**

TRANSFORMER BOBBIN  
INDUSTRIAL CO.,LTD.

ELECTRICAL CO. Tel : 86-750-3867791 Fax : 86-750-3867787

Tel : 86-769-88789999 Fax : 86-769-88789989

e-mail : sales@acore-ferrite.com

http:// tbi-tw.com e-mail : tb6688@ms46.hinet.net

REVISIONS

REV	SYM	DRAFTER	CHECKER	DATE
△		X.H.GU	G.F.YANG	09/07/10
△		X.H.GU	G.F.YANG	10/29/10
△				

TOP

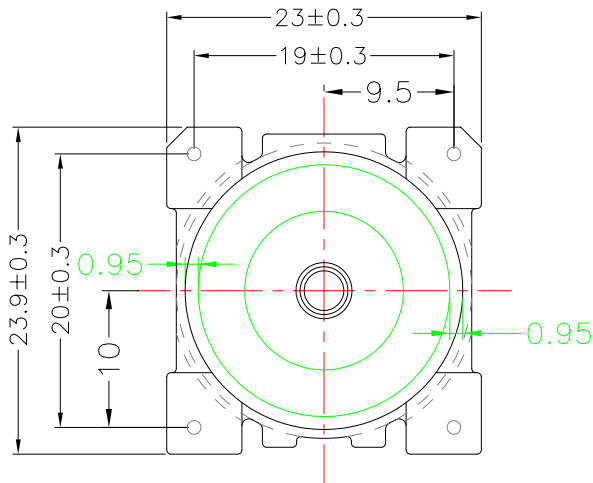

TOP

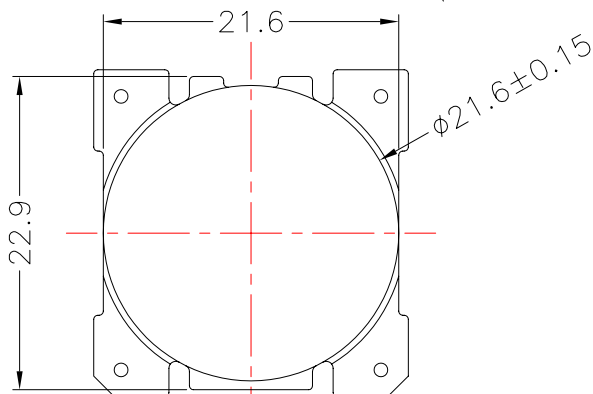
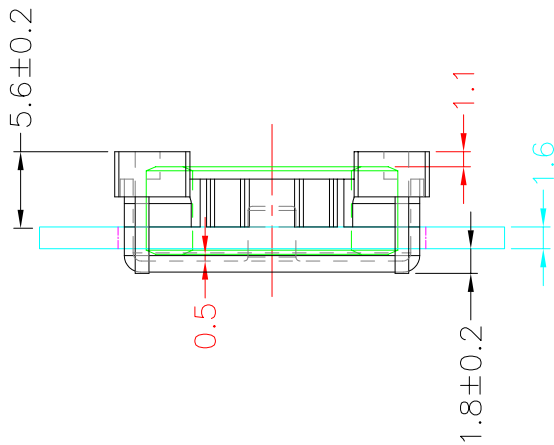
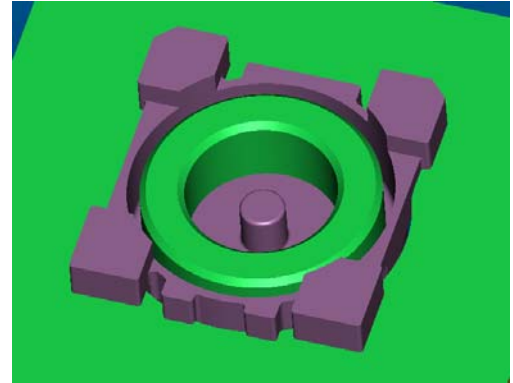

BOTTOM

BOTTOM

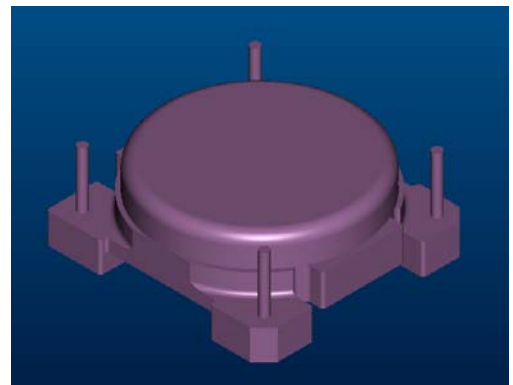

ITEM	PART NO.	MATERIAL	DWG NO.	Core Set Parameters
CORE	OR18X6-12C	JPP-44A		$A_e=17.8\text{mm}^2$ $L_e=45.9\text{mm}$ $C1=2.58\text{mm}^{-1}$ $V_e=817.02\text{mm}^3$
CORE	OR18X6-12C	JPP-95		
BASE	TBI-220-16261.12XX		OR18X6-12C-BASE-B6-12	

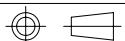

UNIT : m/m

SCALE 1:1

REV 2