

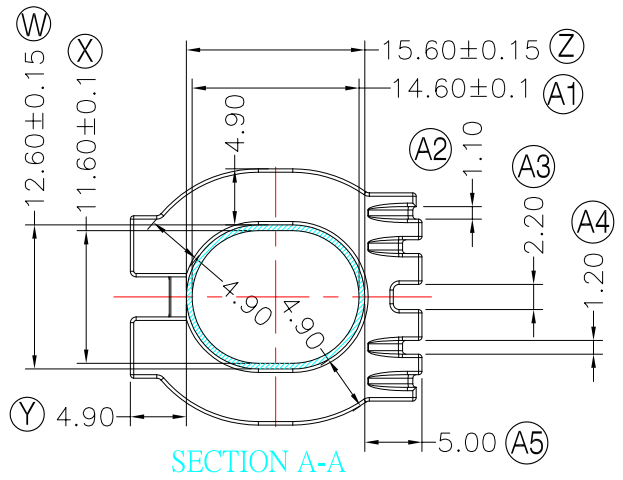

TRANSFORMER BOBBIN
INDUSTRIAL CO., LTD.

Tel : 86-769-88789999 Fax : 86-769-88789989
http://tbi-tw.com e-mail : tb6688@ms46.hinet.net

REVISIONS				
REV	SYM	DRAFTER	CHECKER	DATE
2		M.WANG	G.F.YANG	12/03/16
3				
4				

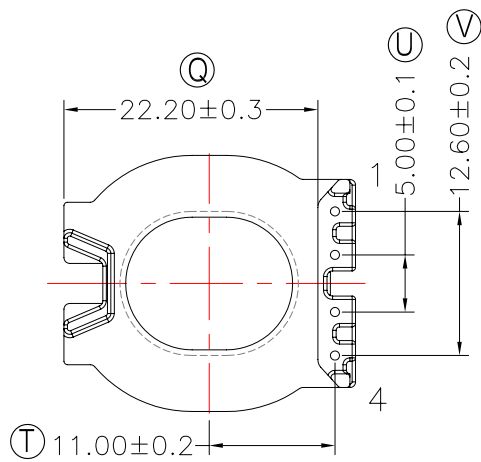
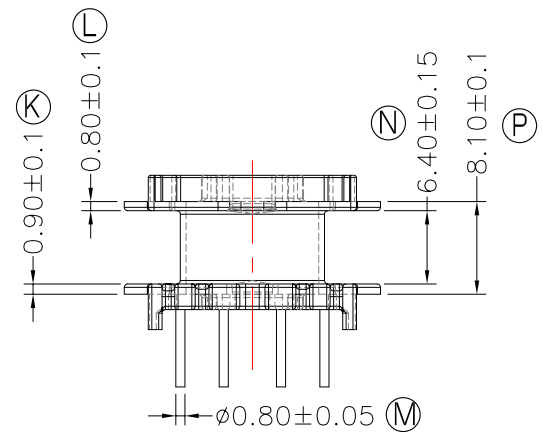
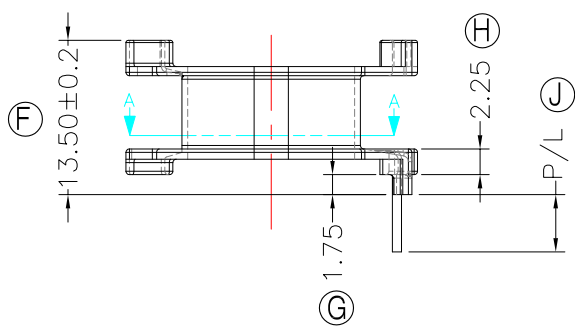
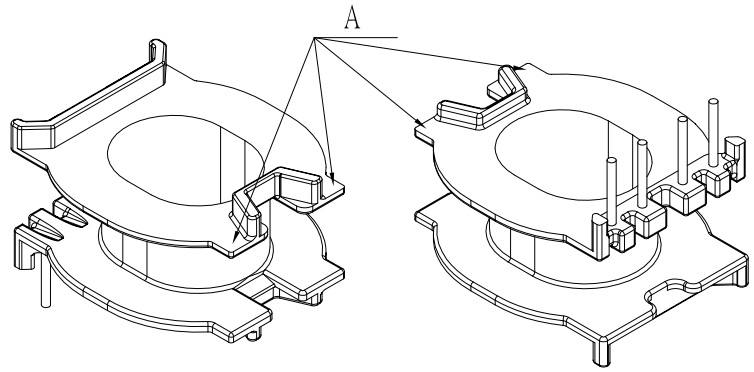
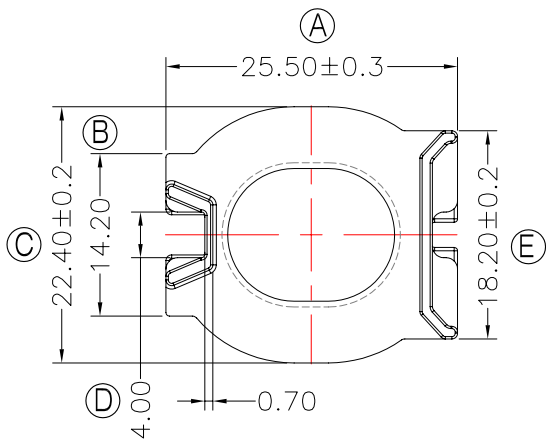

NOTE:

任一點的強度為1.5kg MIN;其中頂部A處為1.3kg MIN;

DWG NO.	ATQ27-14.4-4P-TH-C4-17				
PART NO.	MATERIAL (BOBBIN)	MATERIAL (TERMINAL)	TERMINAL (PLATING)	PIN ALLOCATION	NOTE
TBI-238-03341.1706	PM-9823	CP WIRE	Sn	ALL PIN P/L=4.0±0.2	S
TBI-238-03341.1716	PM-9823	CP WIRE	Sn	ALL PIN P/L=5.0±0.2	H
TOLERANCE: 0<L<=4±0.1 4<L<=16±0.2 16<L<=63±0.3			UNIT : m / m		SCALE 1 : 1

Finish: 1. PB wire Immersion Sn on terminal : Thickness:Sn plating,100%,5 μm (200 μ inches) min,Base nickel 0.625 μm (25 μ inches) min.
2. CP wire Immersion Sn on terminal : Thickness:Sn plating,100%,5 μm (200 μ inches) min.
3. Coplanarity deviation: 0.10 mm (0.004 inches) max.

REV 1