

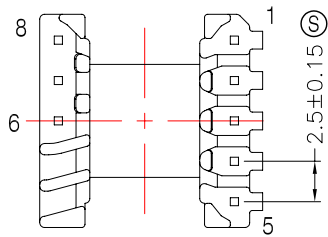

**TRANSFORMER BOBBIN
INDUSTRIAL CO.,LTD.**

Tel : 86-769-88789999 Fax : 86-769-88789989
http:// tbi-tw.com e-mail : tb6688@ms46.hinet.net

REVISIONS				
REV	SYM	DRAFTER	CHECKER	DATE
1		X.H.GU	G.F.YANG	11/29/16
2				
3				

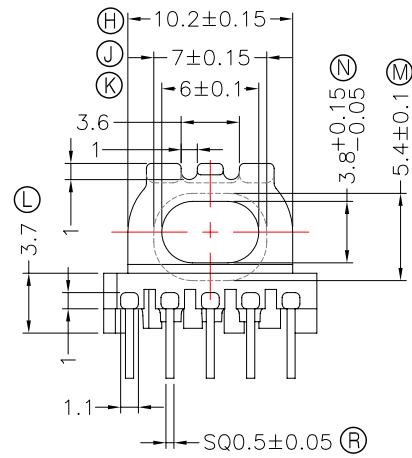
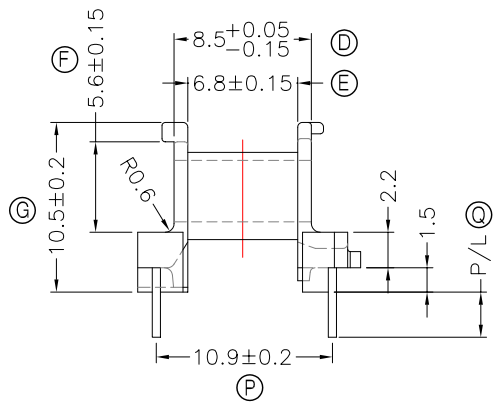
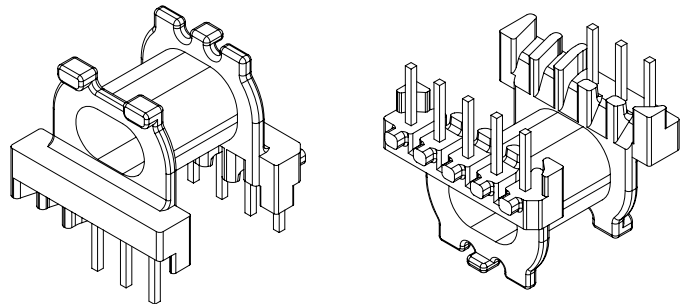
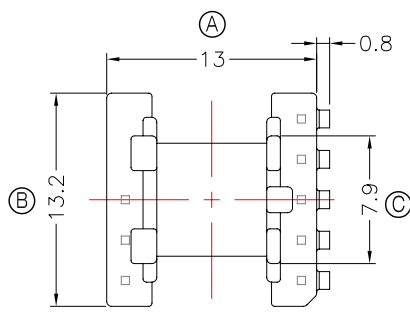

NOTE:

- 1.耐壓4.0Kv /1.5mA 60S;
- 2.焊錫溫度:450°±10° 3SEC
- 3.任意一點強度須1.5kg Min;
- 4.焊錫前拉力:1.0kg Min,焊錫後拉力:1.5kg Min;

DWG NO.	EPC13-13C-8P-TH-B2-17				
PART NO.	MATERIAL (BOBBIN)	MATERIAL (TERMINAL)	TERMINAL (PLATING)	PIN ALLOCATION	NOTE
TBI-206-04221.1706	PM-9823	CP WIRE	Sn	ALL PIN P/L=2.8±0.2	S
TBI-206-04221.1716	PM-9823	CP WIRE	Sn	CUT PIN#3,6,7,8 P/L=2.8±0.2	
TBI-206-04221.1726	PM-9823	CP WIRE	Sn	CUT PIN#3,6,7,8 P/L=2.5±0.2	
TBI-206-04221.1736	PM-9823	CP WIRE	Sn	CUT PIN#2,4,6,7,8 P/L=2.5±0.2	
TBI-206-04221.1746	PM-9823	CP WIRE	Sn	CUT PIN#2,4,6,7,8 P/L=2.8±0.2	
TBI-206-04221.1756	PM-9823	CP WIRE	Sn	ALL PIN P/L=3.3±0.2	
TBI-206-04221.1766	PM-9823	CP WIRE	Sn	CUT PIN#1,3,4,6,7,8 P/L=2.5±0.2	
TBI-206-04221.1776	PM-9823	CP WIRE	Sn	CUT PIN#3,4,6,7,8 P/L=2.8±0.2	
TBI-206-04221.1786	PM-9823	CP WIRE	Sn	CUT PIN#3,4,6,7,8 P/L=2.5±0.2	
TBI-206-04221.1796	PM-9823	CP WIRE	Sn	CUT PIN#2,3,4,5,7 P/L=2.7±0.2	
	TOLERANCE: 0<L<=4:±0.1 4<L<=16:±0.2 16<L<=63:±0.3			UNIT : m / m	SCALE 1 : 1

Finish: 1. PB wire Immersion Sn on terminal : Thickness:Sn plating,100%,5μm (200μ inches) min,Base nickel 0.625μm (25μ inches) min.
2. CP wire Immersion Sn on terminal : Thickness:Sn plating,100%,5μm (200μ inches) min.
3. Coplanarity deviation: 0.10 mm (0.004 inches) max.

REV 1