

A-CORE

A-CORE JIANGMEN ELECTRONICS CO.,LTD
 江門安磁電子有限公司

TBI

TRANSFORMER BOBBIN
 INDUSTRIAL CO.,LTD.

ELECTRICAL CO. Tel : 86-750-3867791 Fax : 86-750-3867787

Tel : 86-769-88789999 Fax : 86-769-88789989

e-mail : sales@acore-ferrite.com

http:// tbi-tw.com e-mail : tb6688@ms46.hinet.net

REVISIONS

REV	SYM	DRAFTER	CHECKER	DATE
△1		X.H.GU	G.F.YANG	08/25/17
△2		X.H.GU	G.F.YANG	10/13/17
△3		X.H.GU	G.F.YANG	01/09/18

TOP

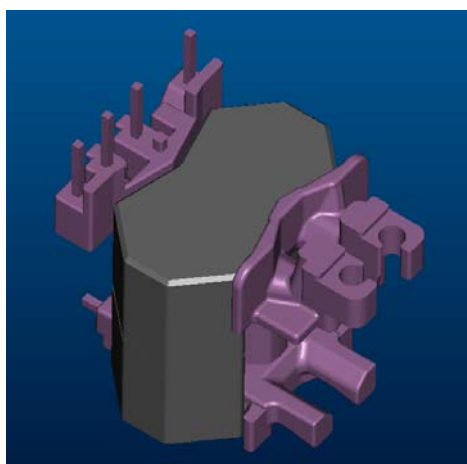
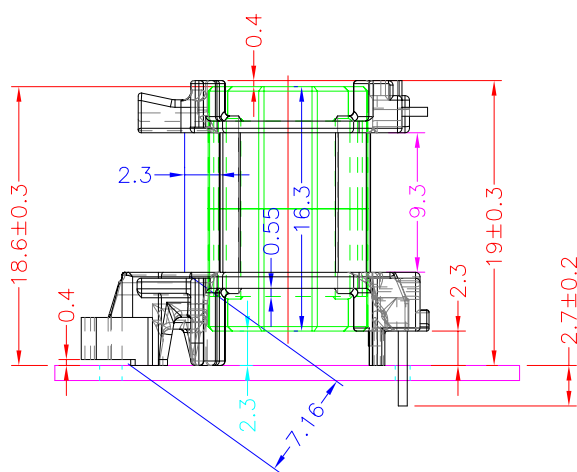
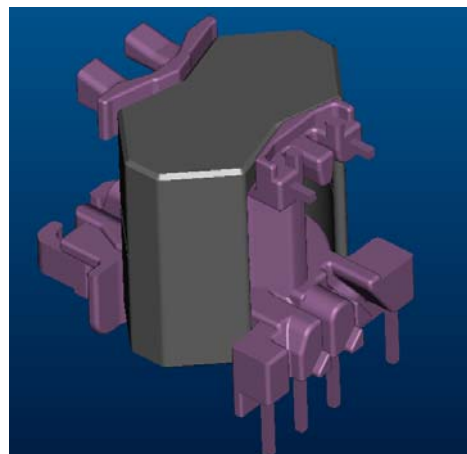
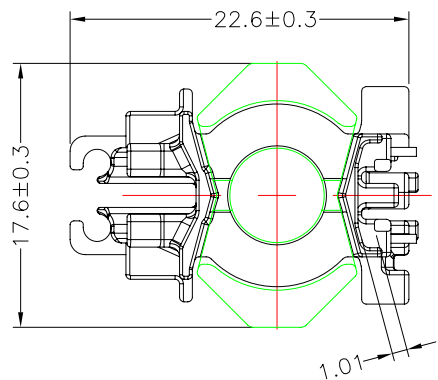

BOTTOM

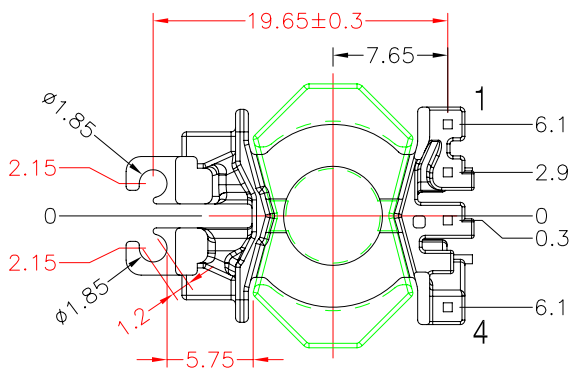

ITEM	PART NO.	MATERIAL	DWG NO.	Core Set Parameters
CORE	RM6/16.3H	JPP-44A		Ae =36.5mm ² Le =38.7mm C1 =1.06mm ⁻¹ Ve=1413mm ³
CORE	RM6/16.3H	JPP-95		
BOBBIN	TBI-208-02251.11XX		RM6-15.7G-6P-TH-B5-11	

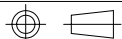

UNIT : m/m

SCALE 1 : 1

REV 3